



SUZUKI
MARINE

Parts Book
DT25 86-88

PREFACE

When it becomes necessary to replace parts on SUZUKI OUTBOARD MOTORS, always use SUZUKI GENUINE PARTS which have passed a strict inspection which guarantees quality and performance.

This parts catalogue covers the list of all service parts for SUZUKI DT25 VG/VH/VJ.

INSTRUCTIONS FOR QUOTING THE CATALOGUE

1. DIMENSIONS

Dimensions of the parts in this catalogue are indicated in unit millimeters.

2. ABBREVIATIONS

Abbreviations used in this catalogue are as follows:

AR	: As required	NT	: Number of teeth
ASSY	: Assembly	OPT	: Optional
E.No.	: Engine number	OS	: Over size
F.No.	: Frame number	STD	: Standard
d	: Diameter of material	Y	: Thickness
ID	: Inside diameter	US	: Under size
OD	: Outside diameter	W	: Width
L	: Length	S,L,UL,LL	: Transom type
LH	: Left hand side		
RH	: Right hand side		
-123456	: Up to F.No.02503-123456		
123456~	: From F.No.02503-123456		
12 x 34 x 5.6Figures in the description column show the dimensions of parts.		
ID	OD	T(or W,L)	

3. INNER PARTS OF ASSEMBLY

Parts number that have a period (.) mark in front of the part description on a text page are separately serviced parts of the assembly.

4. MODIFICATION NOTICE

A parts bulletin will be sent to you on all occasions when changes in parts occur, including interchangeable modifications between new parts and old ones.

5. NOTE

- 5-1. There are some different parts from those of production models among spare parts for the administrative reasons and common use of them with other models.
- 5-2. In respect of rubber hoses and vinyl tubes, please be sure to use them by cutting off according to the length mentioned on parts catalogue or what is actually required on the vehicle.
- 5-3. Note that the drawings on the illustration page are for ready reference of spare parts number, not to be used as an assembly manual. When assembling, use "SUZUKI SERVICE MANUAL".

6. ENGINE NUMBER

DT25 VG : 02503-610947~
DT25 VH : 02503-716001~720217
DT25 VJ : 02503-820218~

7. COLOR

Color No.	:	Color description	:
02M	:	Arctic Silver	:
01Y	:	Francois White-2	:

FIG.1

FIG.1 (B- 2) CYLINDER

Q'TY

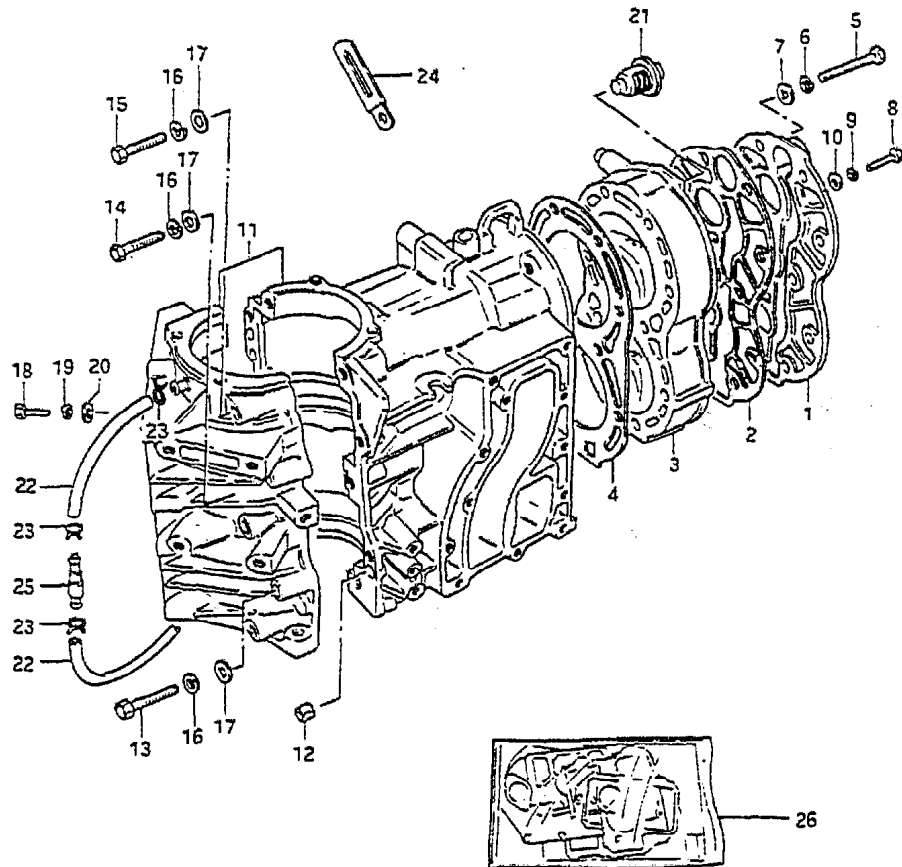

REF.NO.	PART NO.	DESCRIPTION	Q'TY	REMARKS
1	11161-96302-02M	COVER, cylinder head	1	
2	11162-96302	GASKET	1	
3-1	11111-96311-02M	CYLINDER HEAD	1	-614831
3-2	11111-96312-02M	CYLINDER HEAD	1	614832-
4	11141-96302	GASKET	1	
5	01107-08658	BOLT	10	
6	08321-21082	LOCK WASHER	10	
7	08322-11082	WASHER	10	
8	01107-06252	BOLT	2	
9	08321-21062	LOCK WASHER	2	
10	08322-21062	WASHER	2	
11	11301-96306-02M	CYLINDER ASSY	1	
12	04211-09109	.PIN	2	
13	01107-08552	.BOLT	4	
14	01107-08452	.BOLT	2	
15	01107-08602	.BOLT	2	
16	08321-21082	.LOCK WASHER	8	
17	08322-11082	.WASHER	8	
18	01107-06252	.BOLT	4	
19	08321-21062	.LOCK WASHER	4	
20	08322-21062	.WASHER	4	
21-1	17670-94301	THERMOSTAT (50°C)	1	model VG
21-2	17670-93962	THERMOSTAT (50°C)	1	model VH,VJ
22	09343-03051	HOSE (3.1x6.8x330)	2	
23	09401-06403	CLIP	4	
24	09404-06204	CLAMP (L:65)	2	
25	16710-96300	CHECK VALVE	1	
26	11400-96847	GASKET SET	1	OPT

FRD

FIG.2

FIG.2 (8- 3) CRANKSHAFT

Q'TY

REF.NO.	PART NO.	DESCRIPTION	Q'TY	REMARKS
1-1	12110-96303	PISTON, STD	2	
1-2	12110-96353-025	PISTON, OS:0.25	2	OPY
1-3	12110-96353-050	PISTON, OS:0.50	2	OPY
2-1	12140-96301	RING SET, piston, STD	2	
2-2	12140-96351-025	RING SET, piston, OS:0.25	2	OPY
2-3	12140-96351-050	RING SET, piston, OS:0.50	2	OPY
3	12151-92501	PIN, piston	2	
4	09381-18002	SNAP RING	4	
5	09263-18016	BEARING (18x23x22)	2	
6	09169-18001	WASHER	4	
7-1	12200-96306	CRANKSHAFT ASSY	1	-717993
7-2	12200-96307	CRANKSHAFT ASSY	1	717994~
8	12161-96300	.ROD, connecting	2	
9	09263-24018	.BEARING (24x32x20)	2	
10	09181-24001	.WASHER (24x31.5x1)	4	
11	12211-96311	.PIN, crank upper	1	
12	12211-96301	.PIN, crank lower	1	
13	12221-96305	.CRANKSHAFT, upper	1	
14	12232-96304	.WHEEL, MDL crankshaft under	1	
15	12231-96302	.WHEEL, MDL crankshaft upper	1	
16	09160-50002	.WASHER (50x77x1)	1	
17-1	12240-96305	.CRANKSHAFT, under	1	-717993
17-2	12240-96310	.CRANKSHAFT, under	1	717994~
18	09262-30055	.BEARING (30x72x19)	3	
19	09289-38013	.OIL SEAL	1	
20	09283-30011	OIL SEAL (30x55x10)	1	
21	09283-30042	OIL SEAL	1	
22	09282-15004	OIL SEAL (14.7x25x7)	2	

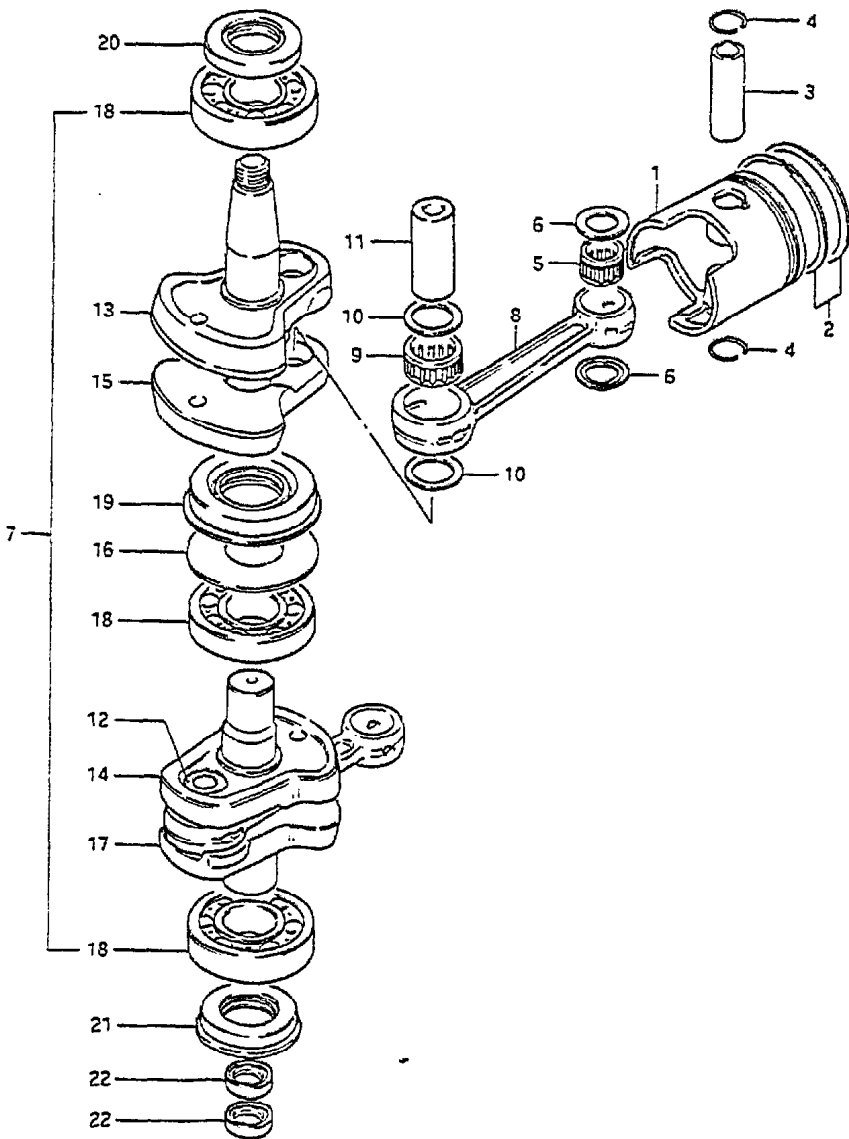
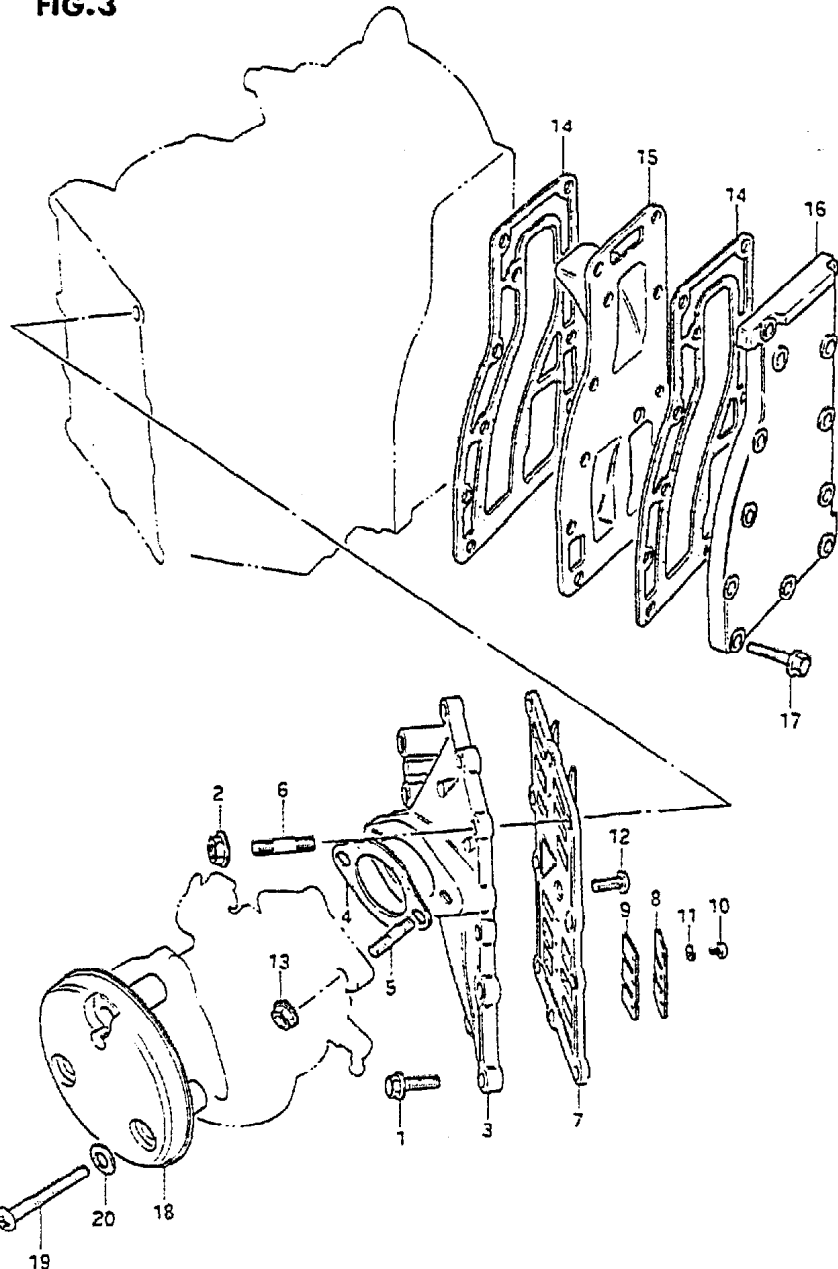

FIG.3

FIG.3 (B- 4) INLET CASE - EXHAUST COVER

Q'TY

REMARKS



REF.NO.	PART NO.	DESCRIPTION	Q'TY	REMARKS
1	01517-06252	BOLT	8	
2	08316-16062	NUT	2	
3	12481-96301-02M	CASE, inlet	1	
4	13125-93000	GASKET, carburetor	1	
5	01411-08202	STUD BOLT	2	
6	01421-06202	STUD BOLT	2	
7	13150-96300	REED VALVE ASSY	1	
8	13152-96300	.STOPPER, reed valve	4	
9	13153-96300	.VALVE, reed	4	
10	02112-03062	.SCREW	12	
11	08321-21032	.LOCK WASHER	12	
12	02122-06162	SCREW	1	
13	08316-16082	NUT	2	
14	14151-96300	GASKET, exhaust cover	2	
15	14131-96301	PLATE, exhaust	1	
16-1	14141-96300-02M	COVER, exhaust	1	-612700
16-2	14141-96301-02M	COVER, exhaust	1	612701-
17	01517-06252	BOLT	12	
18	13811-96300	CASE, silencer	1	
19	02112-06402	SCREW	3	
20	08322-21062	WASHER	3	

FIG.4

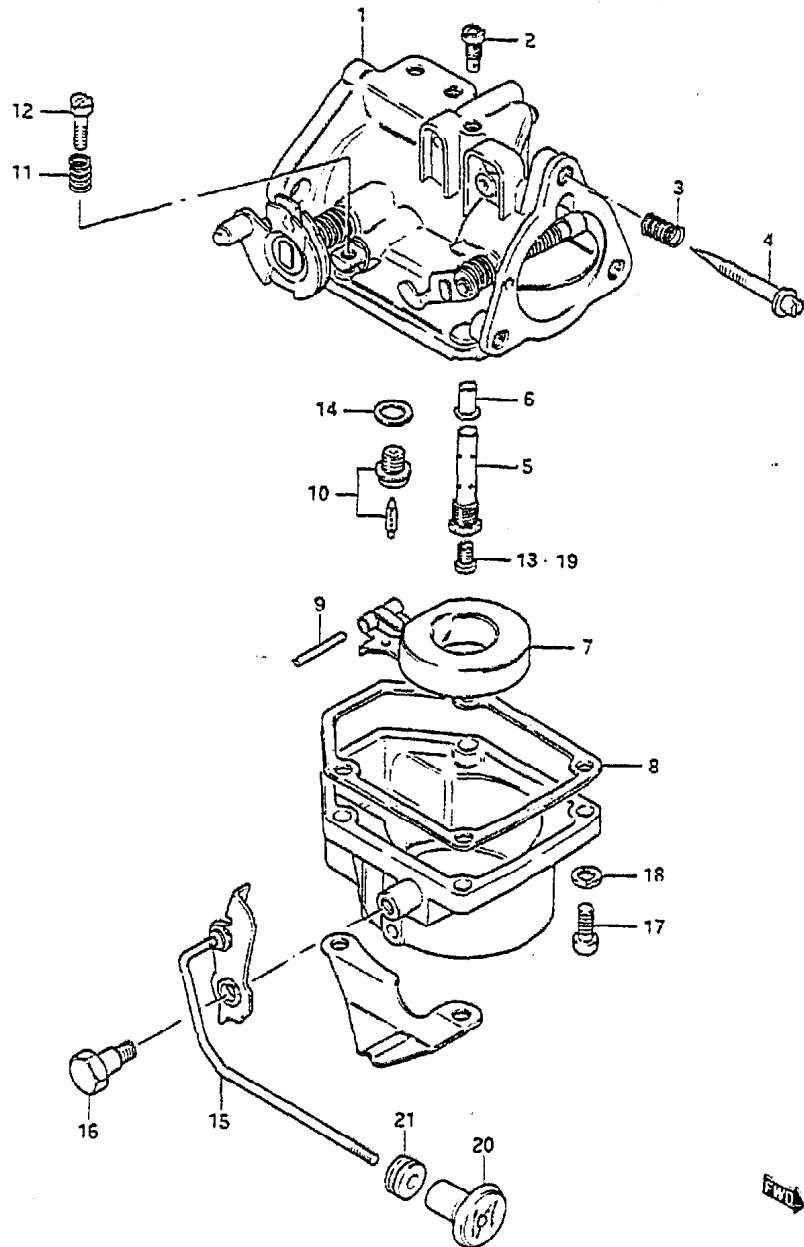

FIG.4 (B- 5) CARBURETOR

Q'TY

REF.NO.	PART NO.	DESCRIPTION	Q'TY	REMARKS
1	13200-96323	CARBURETOR ASSY	1	
2	09492-90002	.JET, air (90)	1	
3	13271-93311	.SPRING, air screw	1	
4	13269-95311	.SCREW, pilot air	1	
5	13236-96300	.NOZZLE	1	
6	13237-94400	.NOZZLE	1	
7	13250-93012	.FLOAT	1	
8	13251-93310	.GASKET, float chamber	1	
9	13254-93010	.PIN, float	1	
10	13370-28110	.VALVE ASSY, needle	1	
11	13268-96110	.SPRING, throttle stop	1	
12	13534-96300	.SCREW, throttle stop	1	
13	09491-28012	.JET, main (142.5)	1	
14	13392-58600	.GASKET, valve seat	1	
15	13681-96300	.LEVER, choke	1	
16	13692-96300	.BOLT	1	
17	02112-05202	.SCREW	4	
18	08321-21052	.LOCK WASHER	4	
19-1	09491-29006	JET, main (145)	1	OPT
19-2	09491-28010	JET, main (140)	1	OPT
19-3	09491-26009	JET, main (130)	1	OPT
19-4	09491-25014	JET, main (125)	1	OPT
20	13631-93500	KNOB, starter	1	
21	09305-04005	BUSH	1	

FWD

FIG.5

FIG.5 (B- 6) UPPER OIL SEAL HOUSING

Q'TY

REF.NO.	PART NO.	DESCRIPTION	Q'TY	REMARKS
1	11411-96301	HOUSING, upper oil seal	1	
2	11413-96300	GASKET	1	
3	02122-06202	SCREW	4	
4	31911-96302-02M	BRACKET, starter	1	ELECTRIC STARTER
5	01107-08252	BOLT	4	ELECTRIC STARTER
6	08321-21082	LOCK WASHER	4	ELECTRIC STARTER
7	08322-11082	WASHER	4	ELECTRIC STARTER

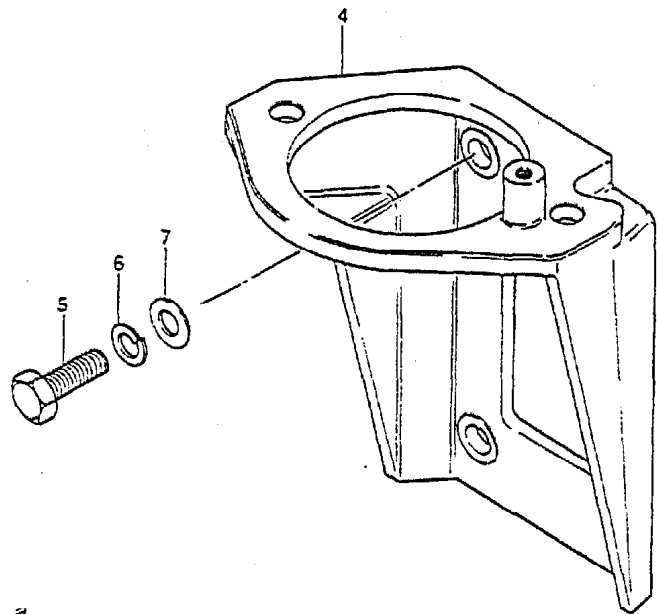
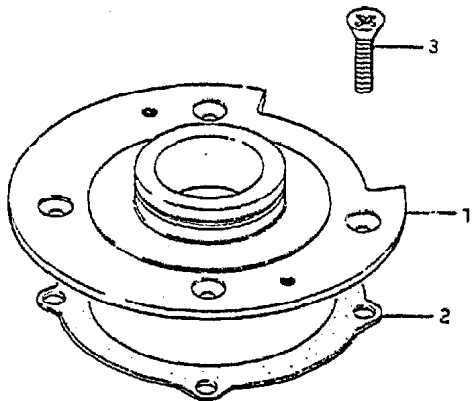

END

FIG.6

FIG.6 (B- 7) FUEL PUMP

Q'TY

REF.NO.	PART NO.	DESCRIPTION	Q'TY	REMARKS
1	15100-94301	PUMP ASSY, fuel	1	
2	15170-94311	.DIAPHRAGM SET	1	
3	15183-94301	.SCREW	2	
4	15186-94300	.NUT	2	
5	15851-94300	.SCREW	3	
6	01107-06402	BOLT	2	
7	08321-21062	LOCK WASHER	2	
8	15321-99700	GASKEY	1	
9	09343-05147	HOSE (5x9x350)	1	L:195
10	09343-05147	HOSE (5x9x350)	1	L:195
11	09401-09402	CLIP	4	
12	15410-93400	FILTER, fuel	1	
13	15415-93400	.O RING	1	
14	15412-93400	.STRAINER	1	
15	15413-93400	.CUP	1	
16	15416-93400	.PACKING	1	
17	08322-21082	WASHER	1	
18	08310-22082	NUT	1	
19	09343-05147	HOSE (5x9x350)	1	L:320
20	09404-06204	CLAMP (L:65)	1	
21	15331-94300	CLIP	2	

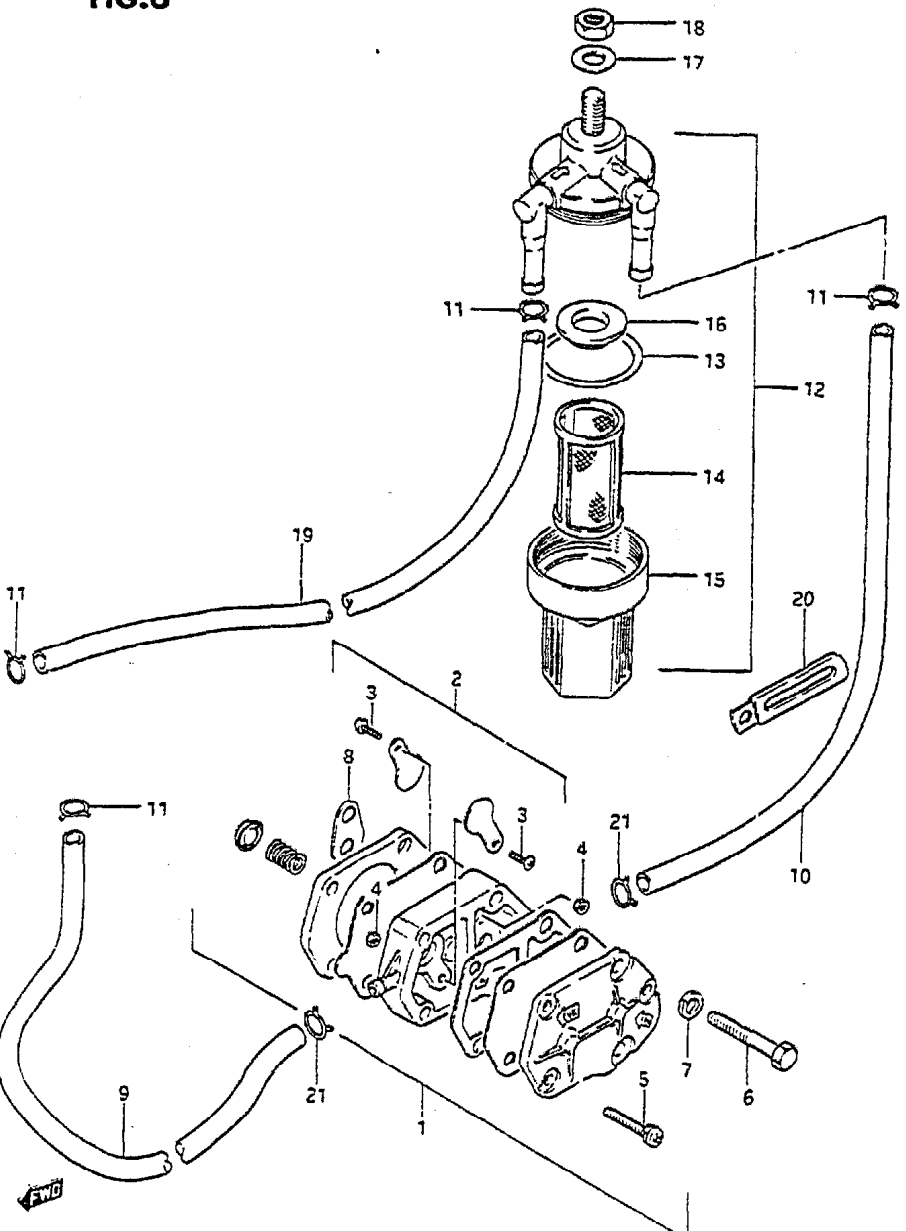
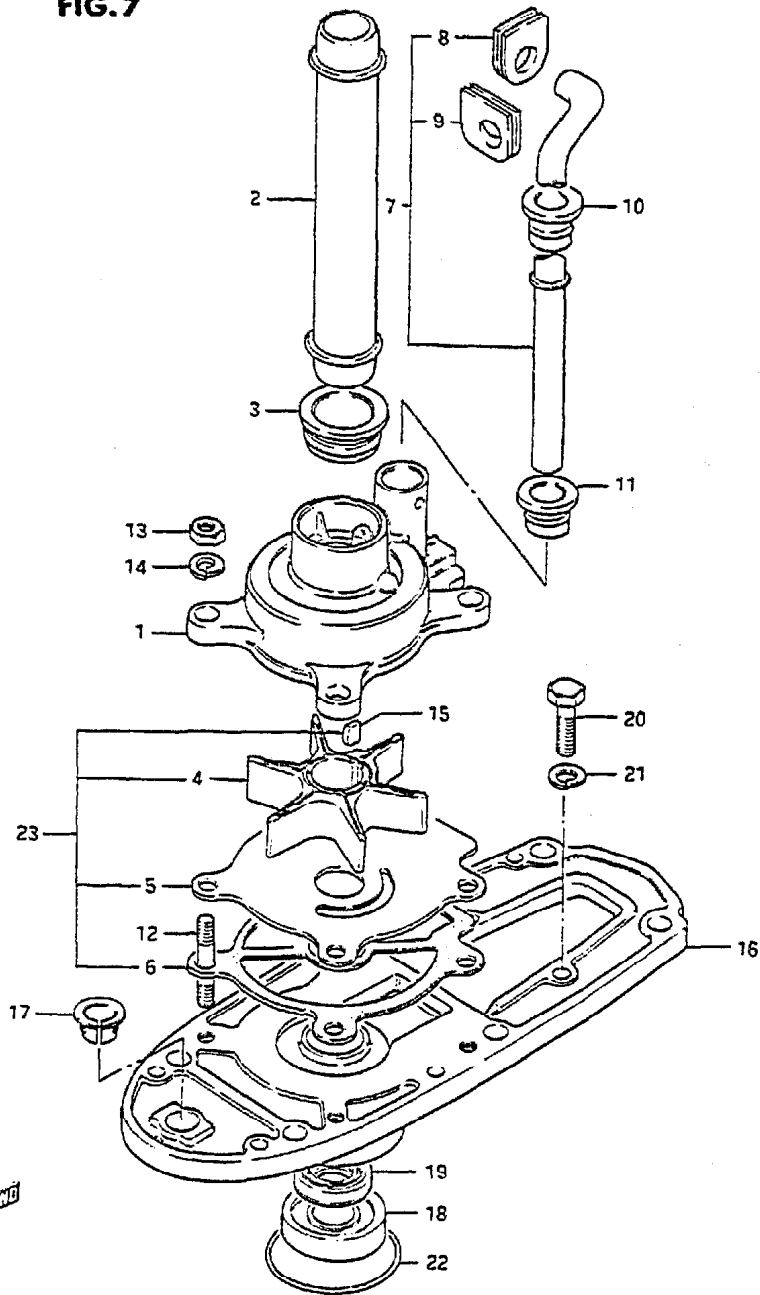

FIG.7

FIG.7 (B- 8) WATER PUMP



Q'TY

REF.NO.	PART NO.	DESCRIPTION	Q'TY	REMARKS
1	17411-94400	CASE, water pump	1	
2-1	17431-96310	TUBE, water pump seal	1	S TYPE
2-2	17431-96300	TUBE, water pump seal	1	L TYPE
3	17432-96300	GROMMET, seal tube	2	
4	17461-96301	IMPELLER, water pump	1	
5	17471-94400	PANEL, under	1	
6	17472-96301	GASKET, pump case lower	1	
7-1	17560-96311	TUBE, water	1	S TYPE
7-2	17560-96301	TUBE, water	1	L TYPE
8	17563-96301	.GROMMET, upper (1)	1	
9	17564-96301	.GROMMET, upper (2)	1	
10	17565-96300	GROMMET, middle	1	
11	17566-96302	GROMMET, lower	1	
12	09108-06007	STUD BOLT, L:25	4	
13	09140-06020	NUT	4	
14	09162-06006	LOCK WASHER	4	
15	09420-04006	KEY	1	
16	56130-96301-02M	HOUSING, drive shaft bearing	1	
17	25214-96302	.BUSH, shifting rod	1	
18	09265-17002	.BEARING	1	
19	09289-17004	.OIL SEAL	1	
20	09100-06103	BOLT	2	
21	09162-06006	LOCK WASHER	2	
22	09280-50005	O RING	1	
23	17400-96350	WATER PUMP REPAIR KIT	1	OPY

FIG. 8

FIG. 8 (B- 9) RECOIL STARTER

Q'TY

REMARKS

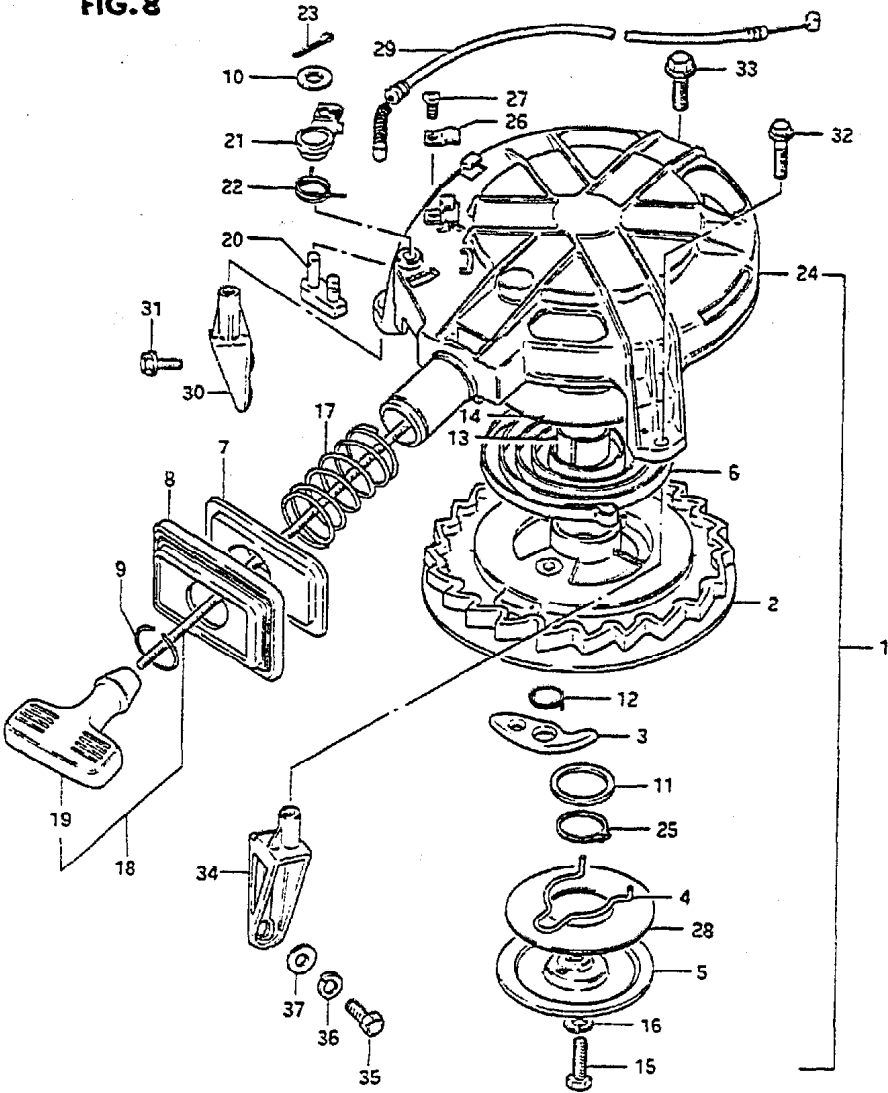

REF.NO.	PART NO.	DESCRIPTION	Q'TY	REMARKS
1	18100-96306	STARTER ASSY, recoil	1	
2	18120-96301	.REEL	1	
3	18131-96301	.RATCHET	1	
4	18153-96300	.SPRING	1	
5	18151-96301	.PLATE	1	
6	18142-96300	.SPRING	1	
7	18191-95202	.PLATE	1	
8	18192-95204	.RUBBER, protector	1	
9	18195-95200	.RING	1	
10	18335-96300	.WASHER	1	
11	18162-96300	.WASHER	1	
12	18155-96301	.SPRING	1	
13	18124-96300	.BUSH	1	
14	18144-96300	.PLATE	1	
15	18332-96300	.BOLT	1	
16	08321-31068	.LOCK WASHER	1	
17	18196-93000	.SPRING, protector	1	
18	18200-95203	.GRIP ASSY	1	
19	18210-93001	..GRIP	1	
20	18281-96300	.LEVER, stopper	1	
21	18282-96300	.ARM, stopper	1	
22	18284-96300	.SPRING	1	
23	18348-96300	.PIN	1	
24	18111-96302	.CASE, starter	1	
25	18255-96300	.SNAP CLIP	1	
26	18291-96300	.HOLDER, cable	1	
27	18342-96300	.SCREW	1	
28	18136-96300	.SPACER	1	

FIG. 8

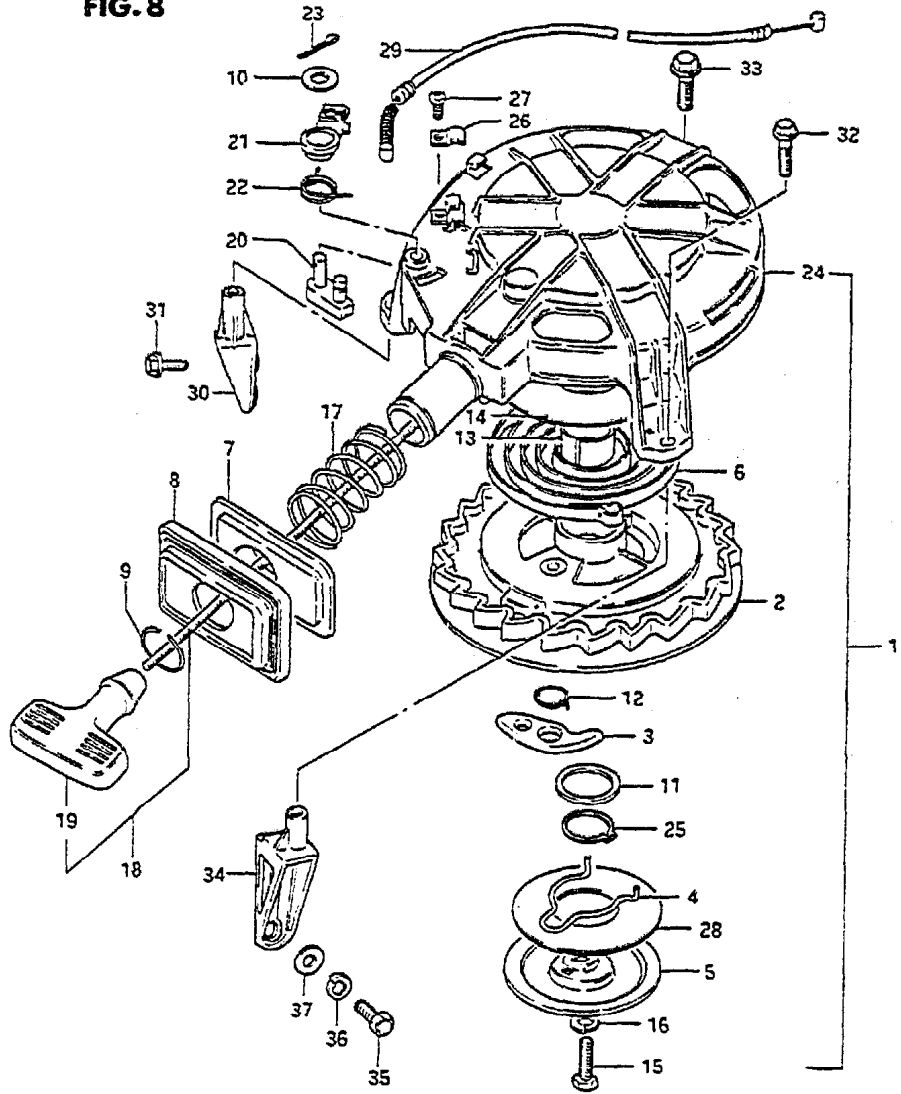

FIG. 8 (B-10) RECOIL STARTER

Q'TY

REF.NO.	PART NO.	DESCRIPTION	Q'TY	REMARKS
29	18290-96301	CABLE, NSI	1	
30	18711-96303-02M	BRACE, recoil starter SYBD	1	
31	01517-06202	BOLT	2	
32	01517-06252	BOLT	2	
33	01517-08252	BOLT	1	
34	18721-96303-02M	BRACE, recoil starter, PORT	1	MANUAL STARTER
35	01107-08252	BOLT	2	
36	08321-21082	LOCK WASHER	2	
37	08322-11082	WASHER	2	

FIG.9

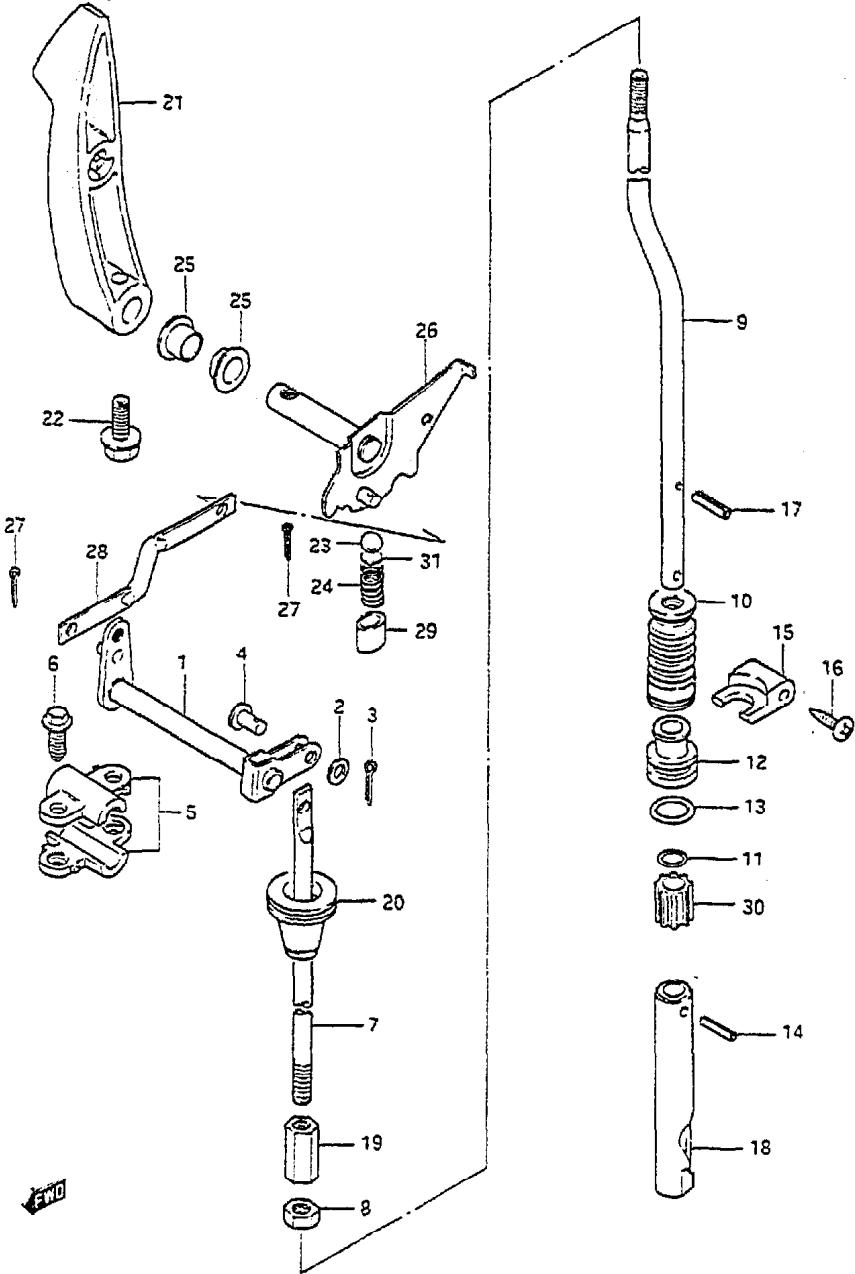
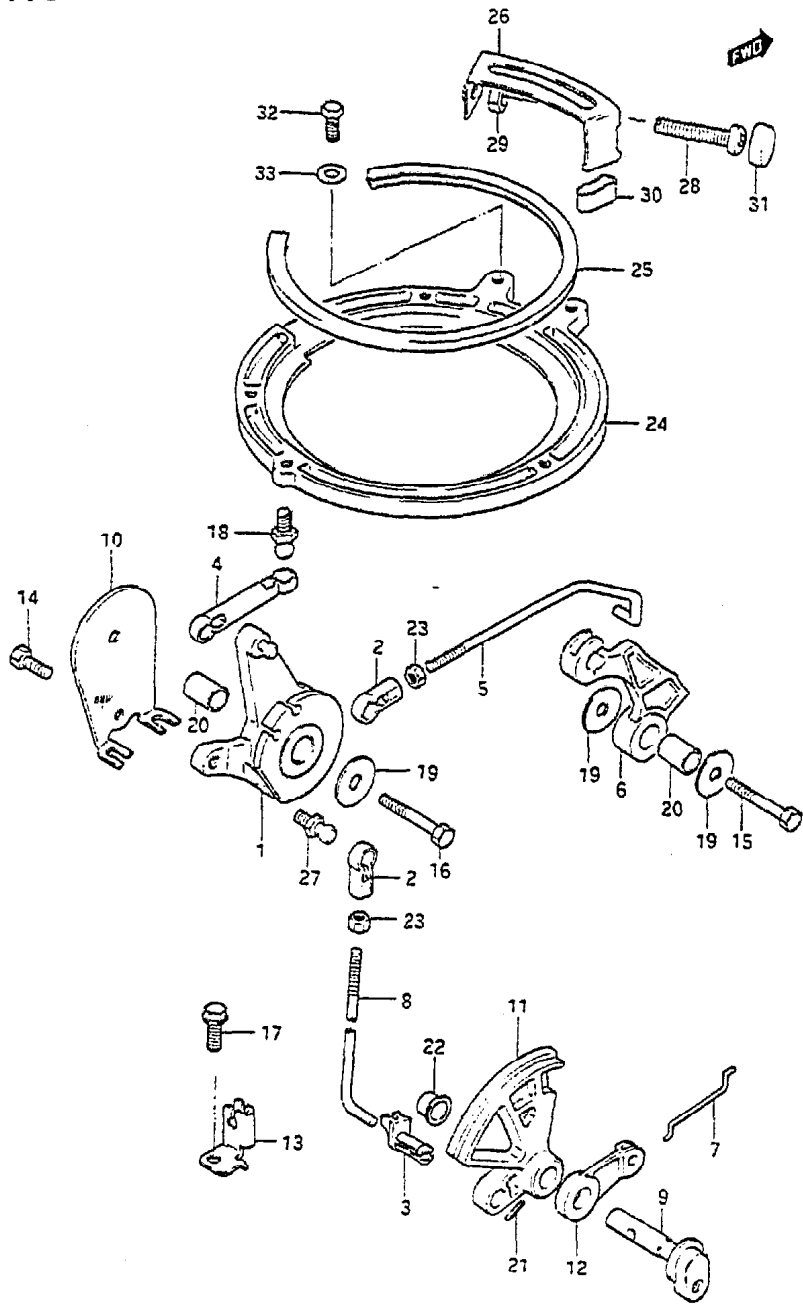

FIG.9 (C- 2) CLUTCH

REF.NO.	PART NO.	DESCRIPTION	Q'TY	REMARKS
1	21210-96300	SHAFT, clutch	1	
2	09160-05010	WASHER (5.5x10x0.8)	1	
3	09204-01001	COTTER PIN	1	
4	09200-05006	PIN	1	
5	21311-96300	HOLDER, clutch shaft	1	
6	01517-06207	BOLT (6x20)	4	
7	23111-96300	ROD, clutch	1	
8	09140-06004	NUT	1	
9-1	25111-96310	ROD, shift	1	S TYPE
9-2	25111-96300	ROD, shift	1	L TYPE
10	25222-96300	BOOT, shift rod	1	
11	09280-08005	O RING	1	
12	25211-96301	GUIDE, shift rod	1	
13	09280-13005	O RING	1	
14	09205-03021	SPRING PIN	1	
15	25215-96301	STOPPER, shift rod guide	1	
16	09139-04004	SCREW	2	
17	09205-02004	SPRING PIN	1	
18	25311-96303	CAM, shift	1	
19	23311-94300	TURNBUCKLE, clutch rod	1	
20	23131-94300	BOOT, clutch rod	1	
21	21111-96302-02M	LEVER, clutch	1	
22	09103-06093	BOLT (6x20)	1	
23	09260-10005	STEEL BALL	1	
24	09440-07021	SPRING	1	
25	09306-10001	BUSH	2	
26	21120-96301	PLATE, clutch notch	1	
27	09204-01002	COTTER PIN	2	
28	21241-96300	ROD, clutch arm	1	
29	25231-96301	SPACER, magnet	1	
30	25232-96301	MAGNET	1	
31	21121-93300	PLATE	1	

FIG.10

FIG.10 (C- 3) THROTTLE CONTROL



Q'TY

REMARKS

REF.NO.	PART NO.	DESCRIPTION	Q'TY	REMARKS
1	19121-96301	LEVER, throttle control	1	
2	19131-95502	CONNECTOR, throttle lever	2	
3	19131-96300	RETAINER, rod connector	1	
4	19132-95500	CONNECTOR	1	
5	19135-96301	ROD	1	
6	19141-96301	CAM, throttle	1	
7	19654-96300	ROD	1	
8	19656-96300	ROD	1	
9	19720-96302	SHAFT, remo-con throttle	1	
10	19761-96300	STAY, throttle cable	1	
11	19811-96301-02M	LIMITER, throttle	1	
12	19851-96301	LEVER, NSI	1	
13	19861-96301	STAY, NSI cable	1	
14	09100-06131	BOLT (6x12)	1	
15	09100-06083	BOLT (6x30)	1	
16	09100-06083	BOLT (6x30)	1	
17	09103-06049	BOLT (6x12)	1	
18	09119-05010	BOLT	1	
19	09160-06046	WASHER (6.5x20x1.5)	3	
20	09180-06105	SPACER (6.1x10x14)	2	
21	09205-04002	SPRING PIN	1	
22	09306-10001	BUSH	1	
23	08310-11052	NUT	2	
24	19151-96300-02M	RETAINER, stator	1	
25	19161-94301	SPACER, stator	1	
26	19172-96302	STOPPER, stator	1	
27	09119-05010	BOLT	1	
28	09139-06015	SCREW	1	
29	09140-06004	NUT	1	
30	09343-07140	CUSHION	1	
31	09329-06002	CUSHION	1	
32	01107-05102	BOLT	2	
33	08322-21052	WASHER	2	

FIG. 11

FIG.11 (C- 4) STARTING MOTOR

Q'TY

REMARKS

REF.NO.	PART NO.	DESCRIPTION	Q'TY	REMARKS
1	31100-96311	MOTOR ASSY, starter	1	
2	31310-96300	.ARMATURE	1	
3	31320-96300	.PINION	1	
4	31312-96300	.STOPPER SET, pinion	1	
5	31360-96300	.WASHER	1	
6	31173-96301	.HOLDER ASSY, brush	1	
7	31131-96300	..BRUSH (+)	1	
8	31132-96300	..BRUSH (-)	1	
9	31135-96300	..SPRING	2	
10	31281-93340	.BOLT	2	
11	02107-08252	BOLT	2	
12	08321-21082	LOCK WASHER	2	
13	08322-11082	WASHER	2	
14	31800-94400	RELAY, starter	1	
15	31805-96350	BRACKET, starter relay	1	
16	01107-06202	BOLT	1	
17	08321-21062	LOCK WASHER	1	
18	38422-94510	DAMPER, starter relay	1	

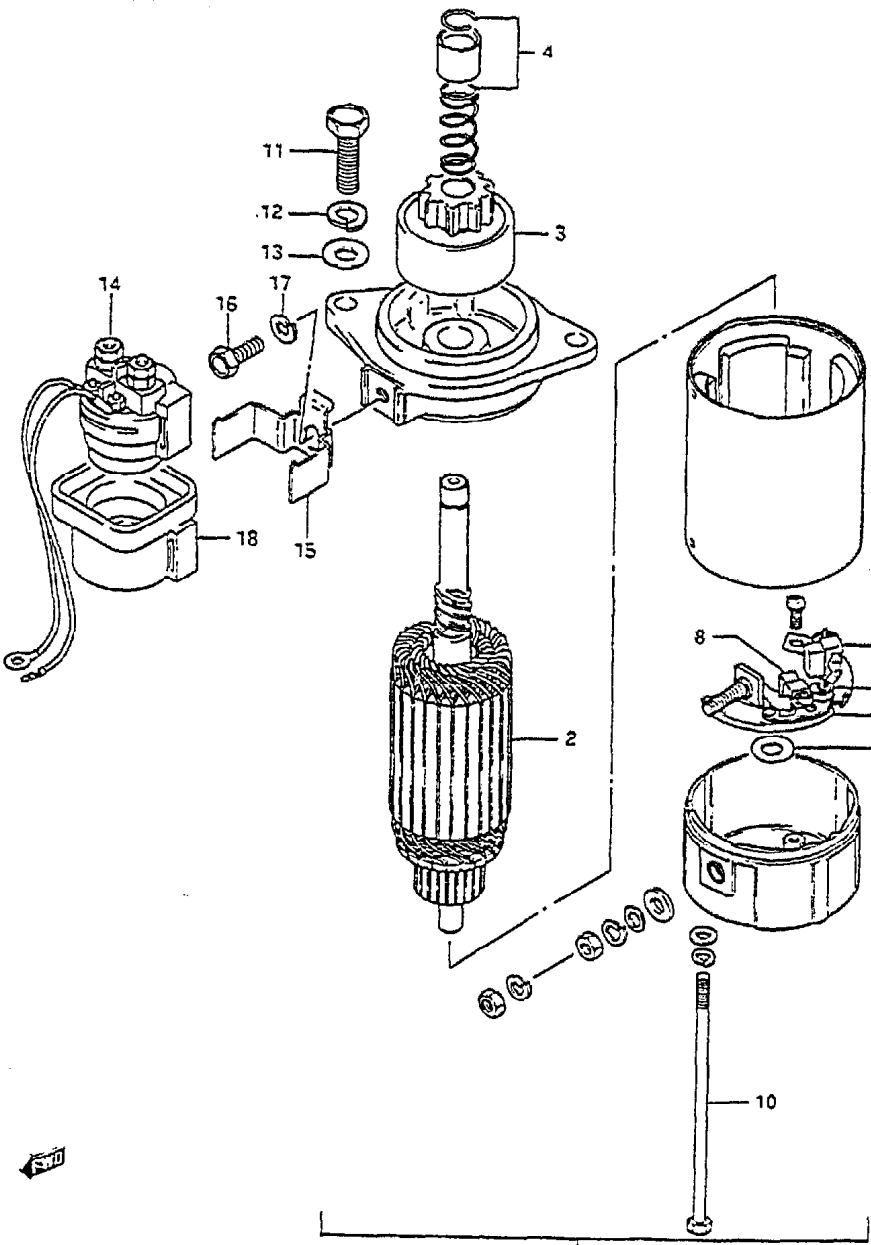
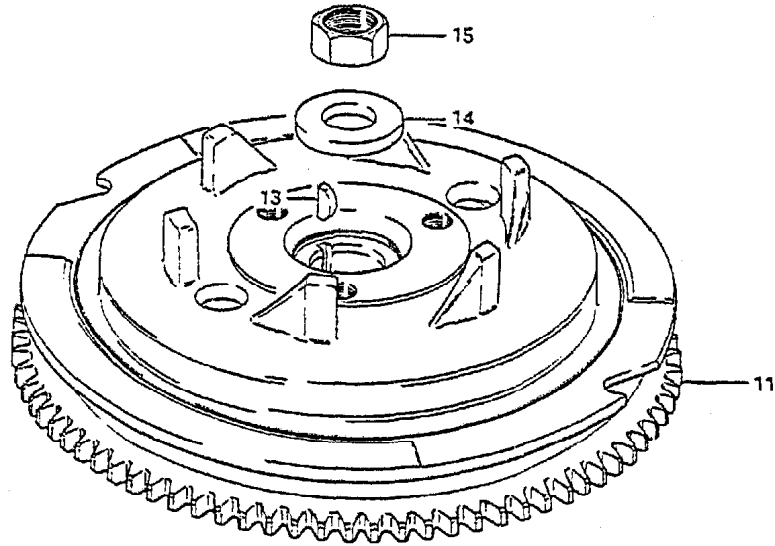

FIG.12

FIG.12 (C- 5) MAGNETO



REF.NO.	PART NO.	DESCRIPTION	Q'TY	REMARKS
1	32101-96340	STATOR ASSY	1	
2-1	32120-96300	.COIL, lighting	1	ELECTRIC STARTER
2-2	32120-96310	.COIL, lighting	1	MANUAL STARTER
3	02112-05252	.SCREW	2	
4	08321-21052	.LOCK WASHER	2	
5	32140-96300	.COIL, ignition	1	
6	02112-05206	.SCREW	2	
7	08321-21052	.LOCK WASHER	2	
8	32150-96310	.SENSOR, ignition	1	
9	02112-04122	.SCREW	2	
10	08321-21042	.LOCK WASHER	2	
11	32102-96380	FLYWHEEL	1	
12	02122-05122	SCREW	3	
13	08341-31049	KEY	1	
14	09160-18011	WASHER (18.5x35x4)	1	
15	08310-22182	NUT	1	

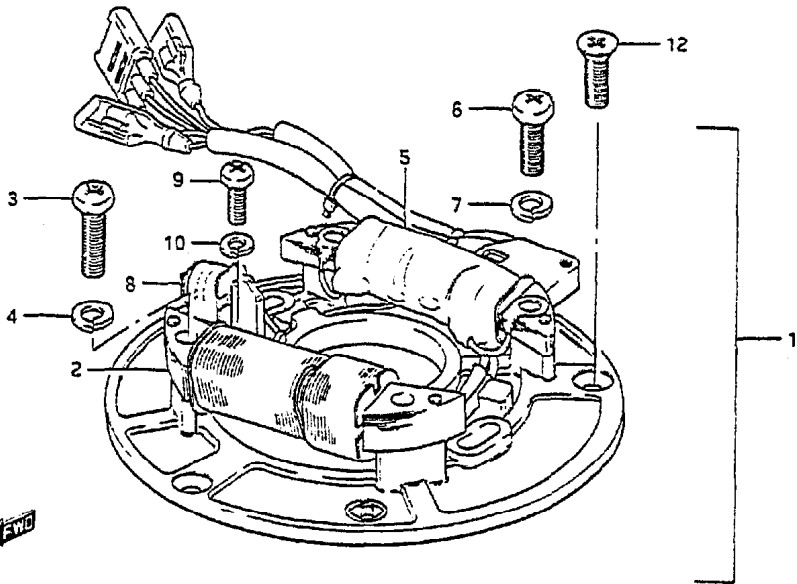

FIG. 13

FIG.13 (C- 6) IGNITION

Q'TY

REF.NO.	PART NO.	DESCRIPTION	REMARKS
1	32900-96340	CDI UNIT / IGNITION COIL ASSY	1
2	09280-62001	O RING	1
3	33510-95510	CAP, spark plug	2
4	09482-00269	SPARK PLUG (B7HS)	2
5	32890-96301	HOLDER, electric parts	1
6	36650-96300	COVER, junction box	1
7	01107-06122	BOLT	3
8	09160-06054	WASHER	3
9	09160-12020	WASHER (12.5x26x1.6)	3
10	09320-12011	CUSHION	3
11	32800-95720	RECTIFIER ASSY	1
12	02112-05252	SCREW	1
13	08310-11052	NUT	1
14	08321-21052	LOCK WASHER	1

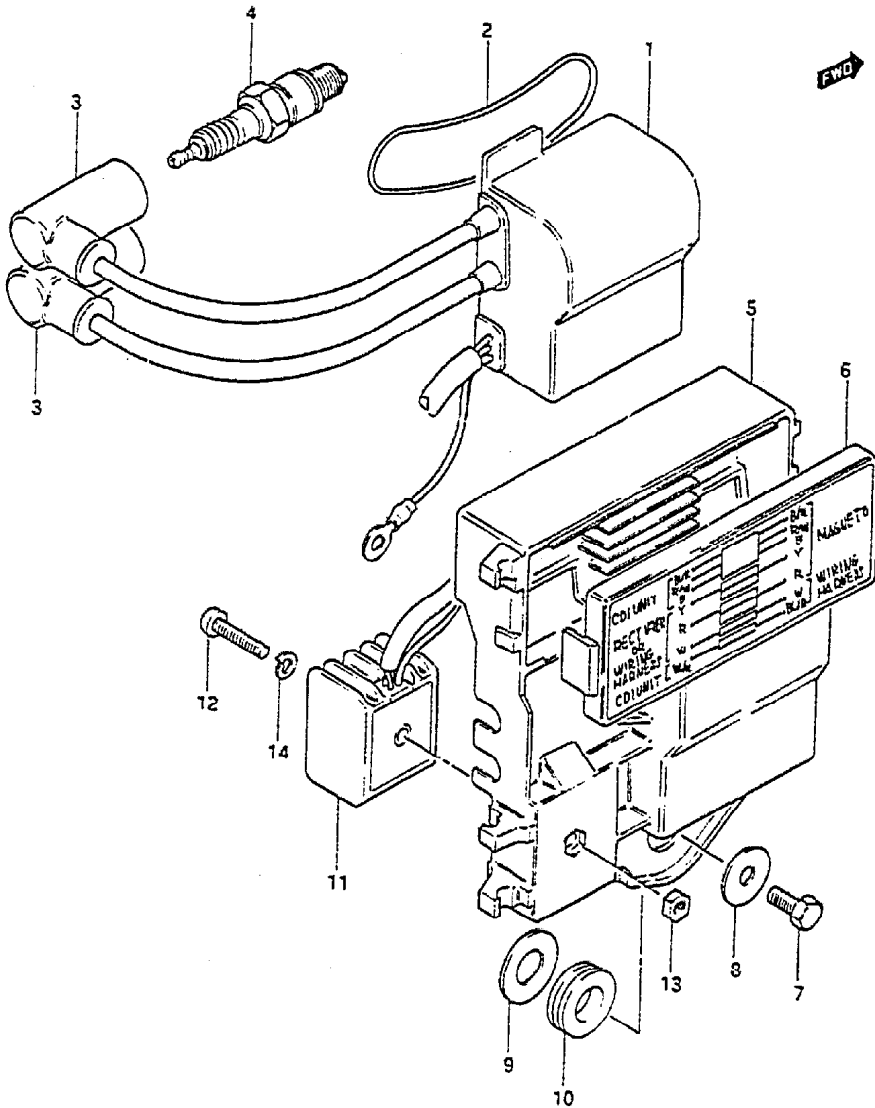

FIG. 14

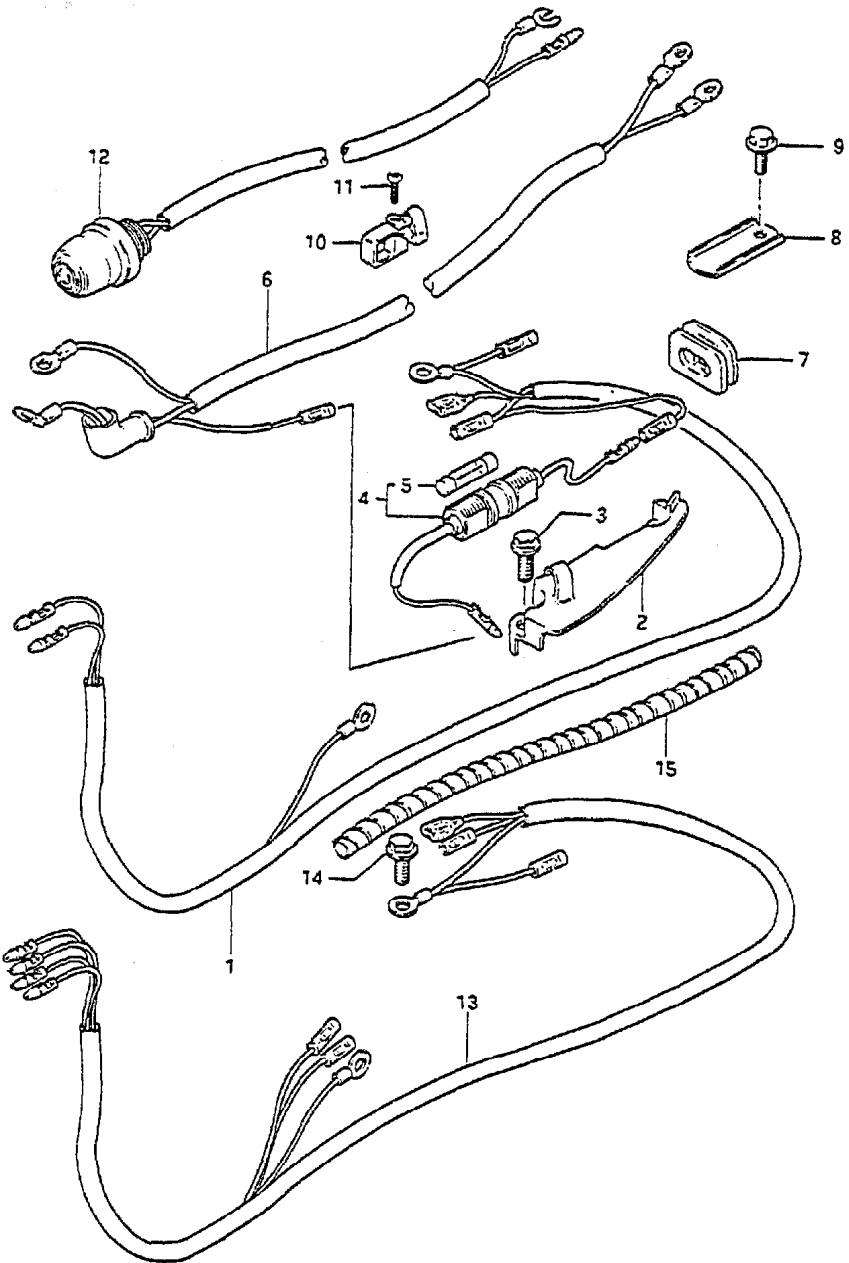

FIG.14 (C- 7) ELECTRICAL

REF.NO.	PART NO.	DESCRIPTION	Q'TY	REMARKS
1	36610-96302	WIRING HARNESS	1	
2	36619-96304	COVER, wiring harness	1	
3	09103-06050	BOLT (6x16)	2	
4	36740-95252	FUSE CASE ASSY	1	
5	09481-20001	.FUSE (20A)	1	
6	33810-96305	CABLE, starter	1	
7	33811-96300	GROMMET, starter cable	1	
8	33815-94501	PROTECTOR, cable	1	
9	09103-06049	BOLT	1	
10	33816-96300	CLAMP, starter cable	1	
11	03242-06259	SCREW	1	
12	37800-93950	SWITCH ASSY, stop (L:840)	1	
13	36899-96302	WIRING HARNESS	1	MANUAL STARTER
14	09103-06049	BOLT (6x12)	1	
15-1	38423-95501	TUBE, wiring harness (L:150)	1	
15-2	33833-95500	TUBE, wiring harness (L:100)	1	

FIG. 15

FIG.15 (C- 8) ELECTRICAL (ELECTRIC STARTER)

Q'TY

REF.NO.	PART NO.	DESCRIPTION	Q'TY	REMARKS
1	37160-96310	SWITCH, start	1	OPT
2	37142-94302	WASHER, ignition switch	2	OPT
3	37721-96354	SWITCH, neutral	1	
4	37725-95300	ACTUATOR, neutral switch	1	
5	37726-96301	BRACKET, neutral switch	1	
6	09100-05104	BOLT	1	
7	09140-05001	NUT	1	
8	38600-96301	SOLENOID, choke	1	OPT-FOR USE WITH REMOTE CONTROL
9	09100-05004	BOLT (5x12)	2	OPT-FOR USE WITH REMOTE CONTROL
10	09160-05010	WASHER (5.5x10x0.8)	2	OPT-FOR USE WITH REMOTE CONTROL
11	09162-05002	LOCK WASHER	2	OPT-FOR USE WITH REMOTE CONTROL

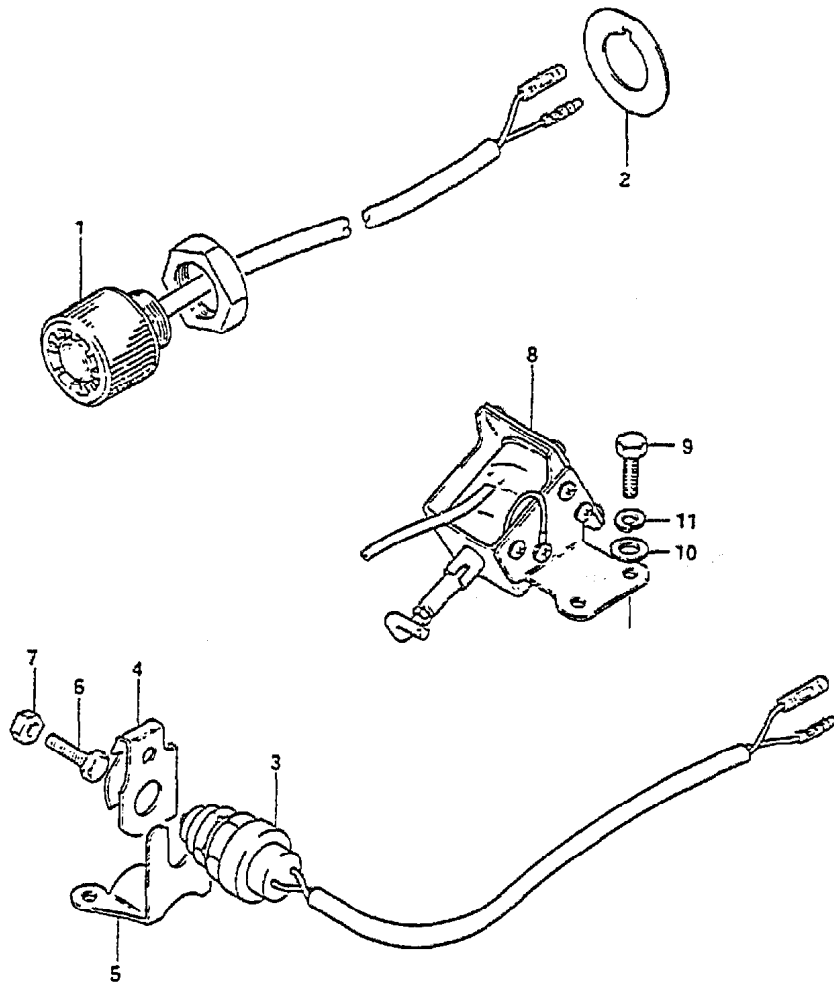
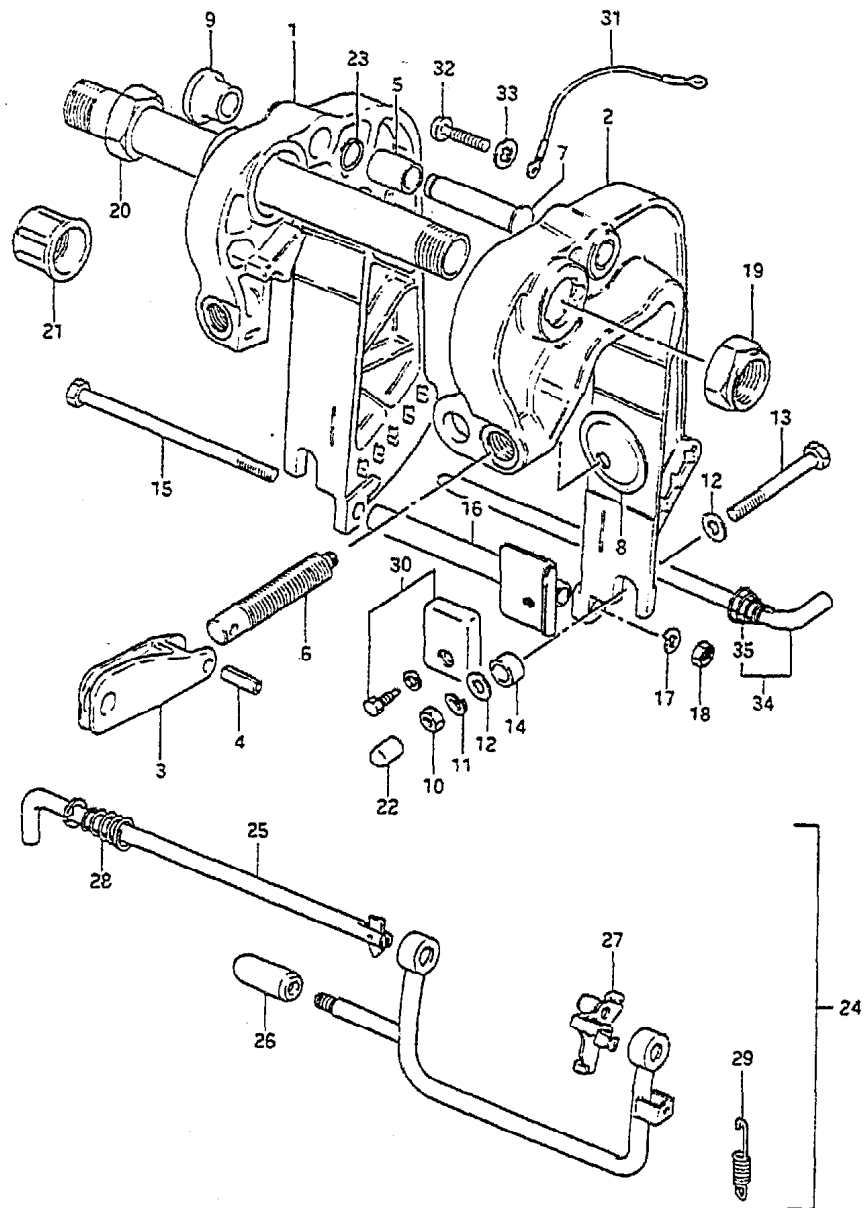

FIG.16

FIG.16 (D- 2) CLAMP BRACKET



REF.NO.	PART NO.	DESCRIPTION	Q'TY	REMARKS
1	41110-96305-02M	BRACKET, clamp STBD	1	
2	41120-96340-02M	BRACKET, clamp PORT	1	
3	41212-93000-02M	HANDLE, clamp	2	
4	09205-06012	SPRING PIN	2	
5	09303-14002	BUSH	1	
6-1	41211-93920	SCREW, clamp (L:90)	2	
6-2	41211-93910	SCREW, clamp (L:78)	2	OPT
6-3	41211-93900	SCREW, clamp (L:68)	2	OPT
7-1	41222-96310	PIN, tilt stopper	1	-717548
7-2	41222-96311	PIN, tilt stopper	1	717549~
8	41213-98100	PLATE, clamp (OO:35)	2	
9	41221-96300	KNOB, tilt stopper	1	
10	09140-08016	NUT	2	
11	09162-08007	LOCK WASHER	2	
12	09160-08081	WASHER (8.5x23x1.5)	4	
13	09100-08239	BOLT (8x90)	2	
14	09180-09016	SPACER (9.2x13.8x9.5)	2	
15	09100-08196	BOLT (8x152)	1	
16-1	41310-96300	ROD, clamp bracket lower	1	model VG,VH
16-2	41310-96301	ROD, clamp bracket lower	1	model VJ
17	09162-08007	LOCK WASHER	1	
18	09140-08016	NUT	1	
19	09159-22003	NUT	1	

FIG. 16

FIG.16 (D- 3) CLAMP BRACKET

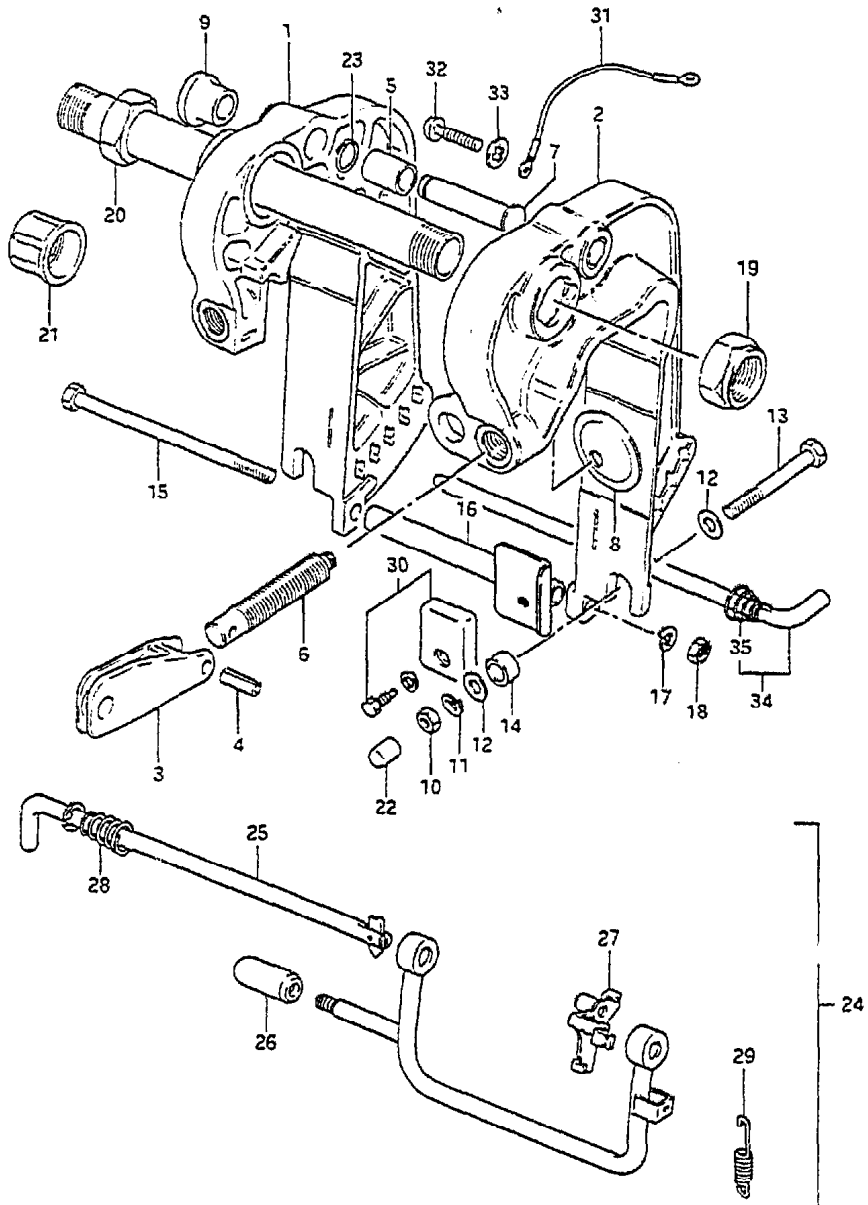

REF.NO.	PART NO.	DESCRIPTION	Q'TY	REMARKS
20	41130-96330	SHAFT, clamp bracket (L:282)	1	
21	41151-94500	CAP, shaft	2	
22	41153-96300	CAP, bolt	2	
23	09380-12005	SPRING	1	
24	45700-96301	SHALLOW DRIVE ASSY	1	model VG,VH
25	45720-96301	.SHAFT, shallow water drive	1	
26	45725-94400	.KNOB	1	
27	45730-96301	.PLATE, shallow water drive	1	
28	09441-17001	.SPRING	1	
29	09443-08045	.SPRING	1	
30	55320-95310	ZINC SET, protection	1	
31	36894-95200	LEAD	1	
32	09125-05050	SCREW	2	
33	09161-05014	WASHER	2	
34	45420-96310	PIN, tilt lock	1	model VJ
35	09441-17001	.SPRING	1	model VJ

FIG. 17

FIG.17 (D- 4) SWIVEL BRACKET

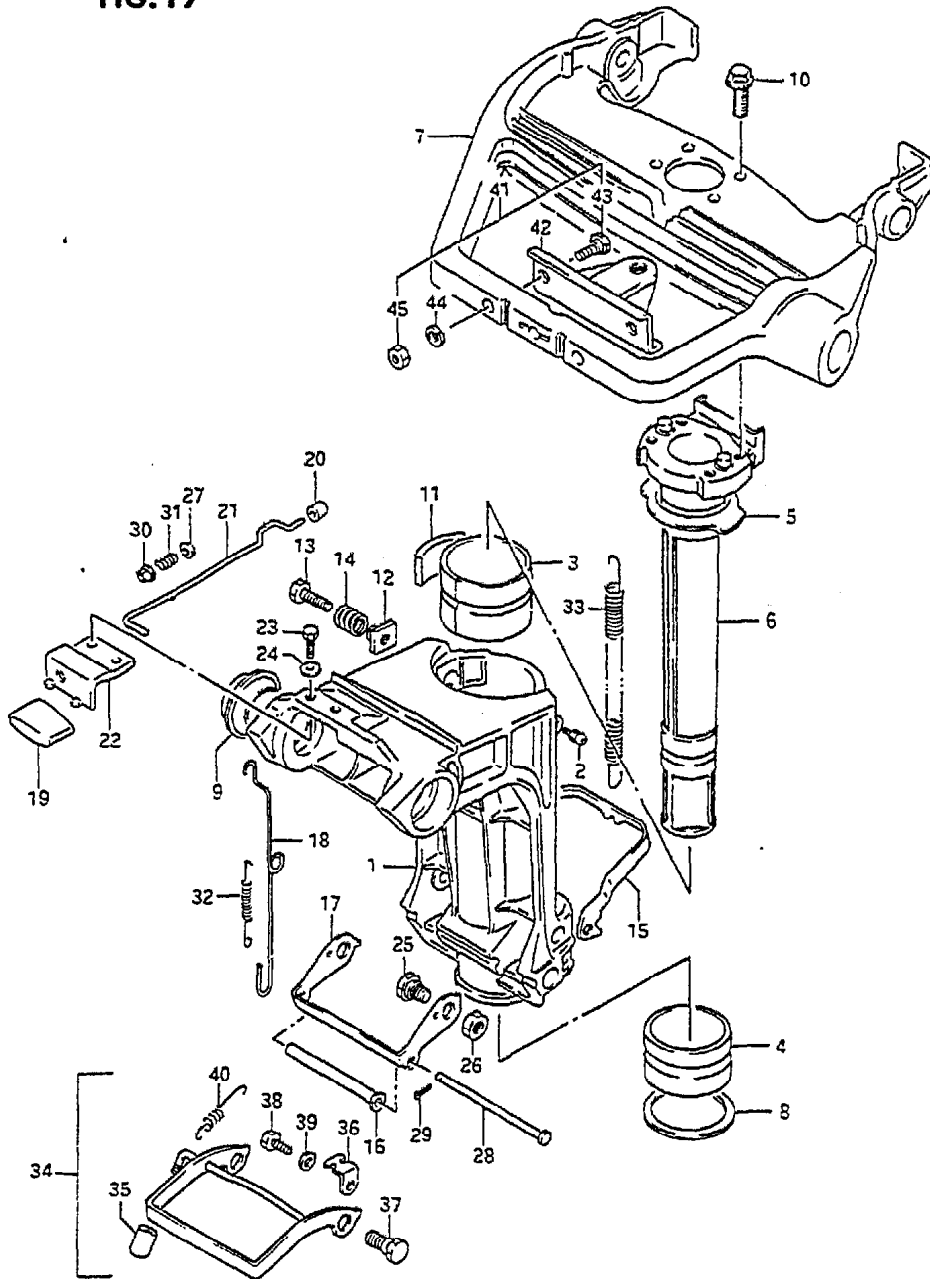

Q'TY

REMARKS

REF.NO.	PART NO.	DESCRIPTION	Q'TY	REMARKS
1-1	43111-96311-02M	BRACKET, swivel	1	model VG,VH
1-2	43111-96320-02M	BRACKET, swivel	1	model VJ
2	22511-99001	NIPPLE, clutch body	4	
3	43711-96301	BUSH, steering upper	1	
4	43712-96301	BUSH, steering under	1	
5	43721-96301	PLATE, upper bush	1	
6	43741-96302-02M	SHAFT, pilot	1	
7	43751-96303-02M	BRACKET, steering	1	
8	09160-40005	WASHER (40x58x2)	1	
9	09306-22004	BUSH	2	
10	09103-08123	BOLT	4	
11	43411-96300	ADJUSTER, steering	1	
12	43421-96301	BUSH	1	
13	09119-08044	BOLT	1	
14	09440-13045	SPRING	1	
15	45231-96303	ARM, reverse lock	1	
16	45246-96302	SPACER	1	
17	45241-96303	LINK, reverse lock arm	1	
18	45252-96302	LINK, release lever	1	
19	45255-96300	KNOB, release lever	1	
20	45257-96300	BUSH, release lever	1	
21	45260-96300	LEVER, release	1	
22	45311-96302-02M	BRACKET, release lever	1	
23	09100-05011	BOLT (5x12)	2	
24	09160-05010	WASHER	2	
25	09111-10034	BOLT	2	
26	09140-10032	NUT	2	
27	09160-04012	WASHER (4.2x10x1)	1	
28	09200-05011	PIN	1	
29	09204-01031	COTTER PIN	1	
30	09319-04001	BUSH	1	

FIG. 17

FIG. 17 (D- 5) SWIVEL BRACKET

Q'TY

REF.NO.	PART NO.	DESCRIPTION	Q'TY	REMARKS
31	09440-04021	SPRING	1	
32	09443-05013	SPRING	1	
33	09443-09016	SPRING	1	
34	45700-96311	SHALLOW WATER DRIVE SET	1	model VJ
35	45255-95500	.KNOB, shallow drive	1	
36	45731-96310	.PLATE, shallow drive	1	
37	09111-10032	.BOLT	2	
38	09100-06113	.BOLT	1	
39	09162-06001	.LOCK WASHER	1	
40	09443-08031	.SPRING	1	
41	67100-96300	ATTACHMENT SET	1	OPT
42	43755-96301	.ATTACHMENT, steering bracket	1	OPT
43	09100-08224	.BOLT (8x35)	2	OPT
44	09162-08007	.LOCK WASHER	2	OPT
45	09140-08016	.NUT	2	OPT

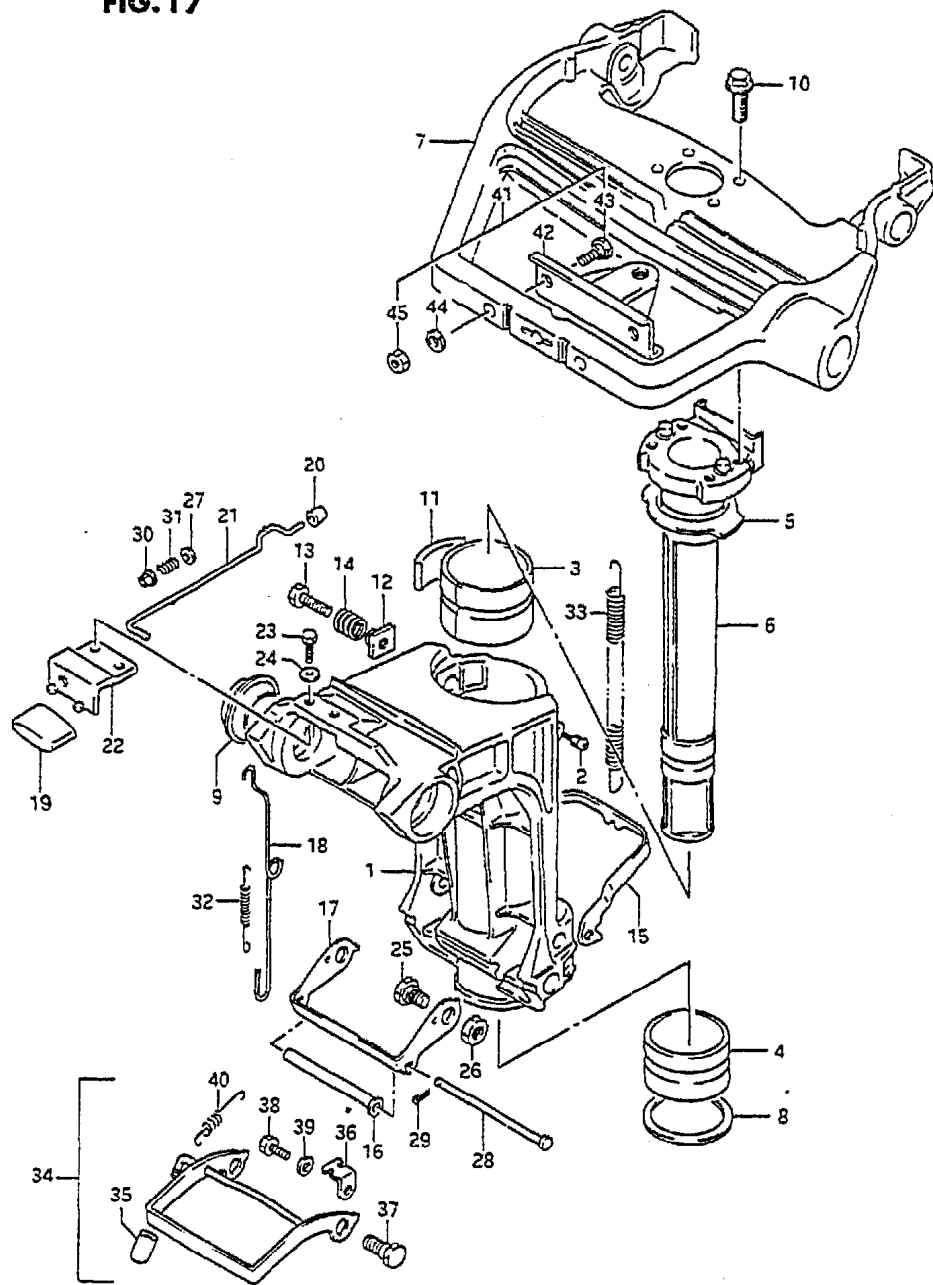
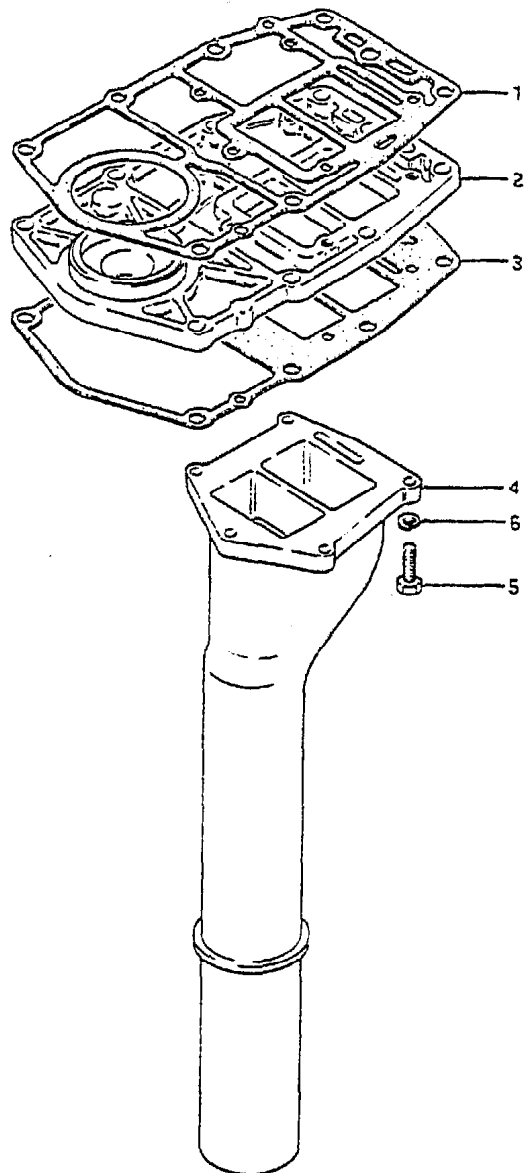

FIG.18

FIG.18 (D- 6) EXHAUST TUBE



REF.NO.	PART NO.	DESCRIPTION	Q'TY	REMARKS
1	11433-96302	GASKET, lower oil seal housing	1	
2	11431-96310	HOUSING, under oil seal	1	
3	52113-96304	GASKET, drive shaft housing	1	
4-1	14211-96330	TUBE, exhaust	1	L TYPE
4-2	14211-96340	TUBE, exhaust	1	S TYPE
5	09100-06117	BOLT (6x35)	5	
6	09162-06006	LOCK WASHER	5	

← FWD

FIG. 19

FIG.19 (D- 7) DRIVESHAFT HOUSING

Q'TY

REF.NO.	PART NO.	DESCRIPTION	Q'TY	REMARKS
1	09202-06015	PIN	2	
2	09160-08015	WASHER	8	
3	09162-08007	LOCK WASHER	8	
4	09100-08203	BOLY (8x85)	4	
5	09100-08204	BOLY (8x50)	4	
6-1	52111-96321-02M	HOUSING, drive shaft (S)	1	-614534 52111-96322-02M W/52117-94400
6-2	52111-96322-02M	HOUSING, drive shaft (S)	1	614535-720217
6-3	52111-96323-02M	HOUSING, drive shaft (S)	1	model VJ
6-4	52111-96330-02M	HOUSING, drive shaft (L)	1	-614549 52111-96331-02M W/52117-94400
6-5	52111-96331-02M	HOUSING, drive shaft (L)	1	614550-720217
6-6	52111-96332-02M	HOUSING, drive shaft (L)	1	model VJ
7	54121-96300	MOUNTING, upper thrust reverse	1	
8	09100-06102	BOLT	4	
9	09162-06006	LOCK WASHER	4	
10	54137-96301-02M	COVER, upper mounting	2	
11	54130-96310	MOUNTING, upper	2	
12-1	09100-10176	BOLT (10x75)	2	model VG
12-2	09100-10260	BOLT	2	model VH, VJ
13	09160-10082	WASHER (10.5x19x2)	4	
14	09159-10050	NUT	2	
15	54160-96310	MOUNTING, lower	2	
16	54165-96310	DAMPER, reverse stopper	2	
17	54166-96301	BOLT, lower mounting	2	
18	09140-10032	NUT	2	
19	09160-10083	WASHER (10.5x30x3.2)	2	
20	54221-96301-02M	COVER, lower mounting	2	

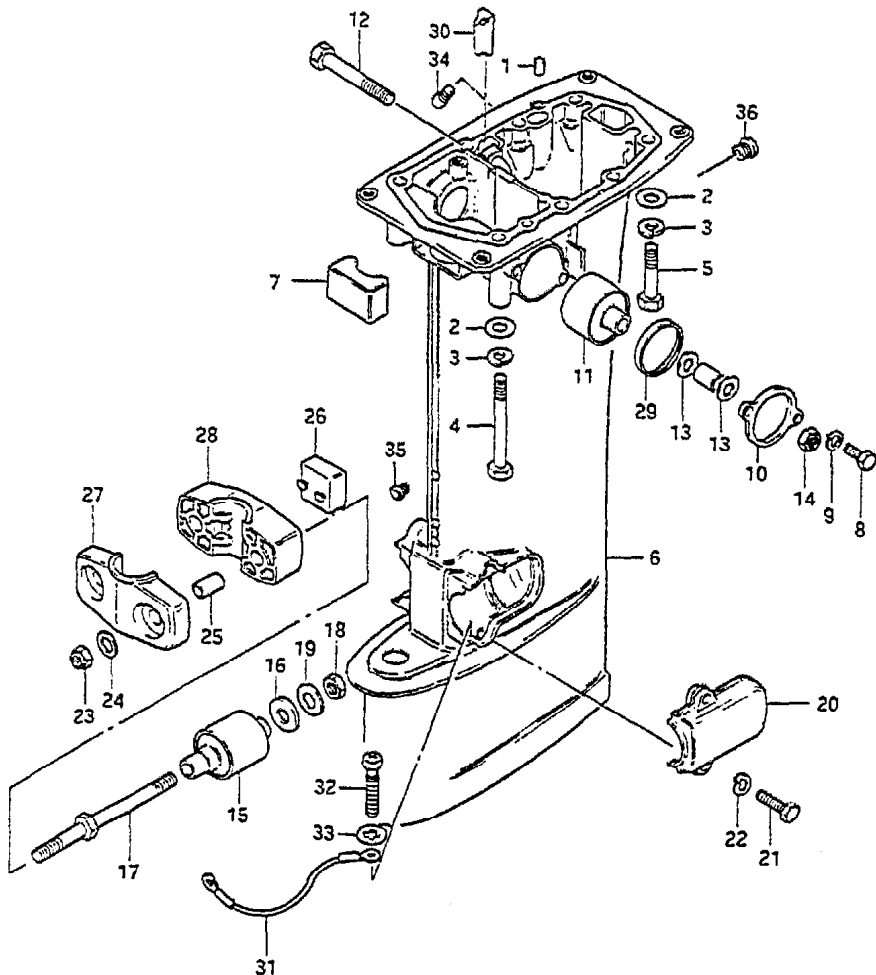

576

FIG. 19

FIG.19 (D- 8) DRIVESHAFT HOUSING

Q'TY

REMARKS

REF.NO.	PART NO.	DESCRIPTION	Q'TY	REMARKS
21	09100-06104	BOLT	4	
22	09162-06006	LOCK WASHER	4	
23	09159-10050	NUT	2	
24	09160-10082	WASHER (10.5x13.8x19)	2	
25	09180-10102	SPACER (10.1x13.8x19)	2	
26	54151-96300	MOUNTING, lower thrust	1	
27	54211-96310-02M	BRACKET, lower mount foward	1	
28	54212-96302-02M	BRACKET, lower mount aft	1	
29	54138-96300	SLEEVE, upper mounting	2	
30	17568-96300	PLUG	1	
31	36894-95200	LEAD	1	
32	09125-05050	SCREW	2	
33	09161-05014	WASHER	2	
34	52117-94400	TUBE, water insp	1	
35	52124-93900	BUSH, driveshaft hous No.1	3	model VJ
36	52125-96300	BUSH, driveshaft hous No.2	2	model VJ

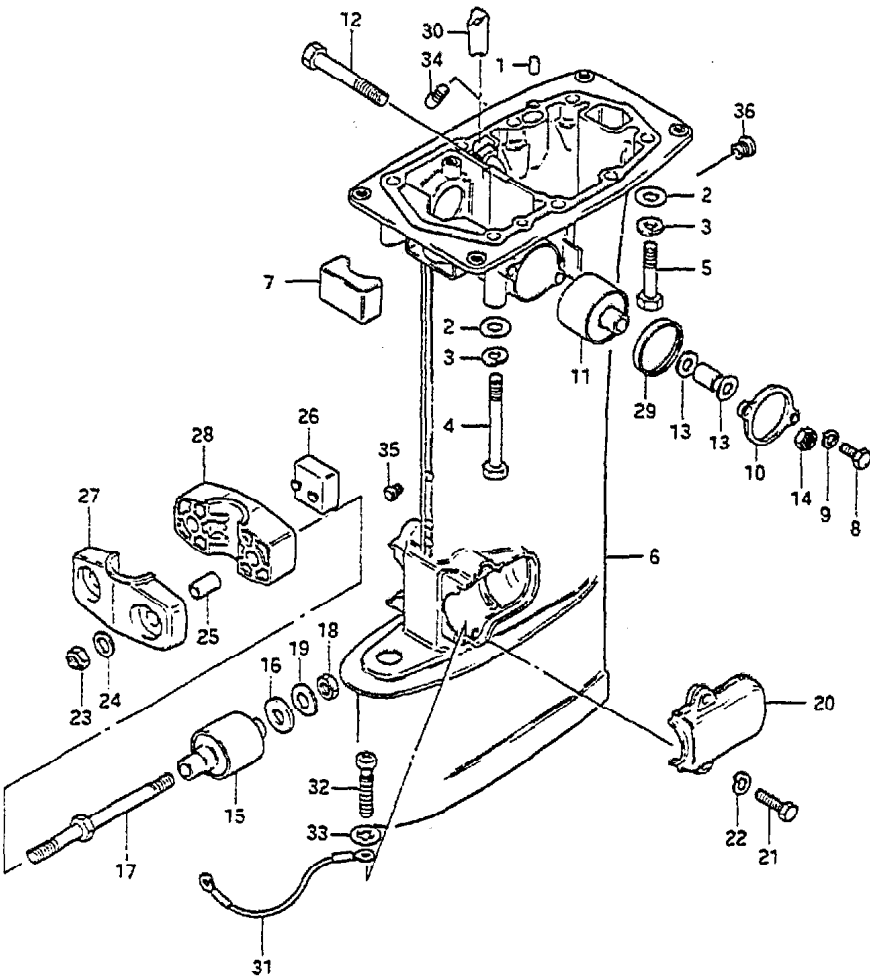

FIG. 20

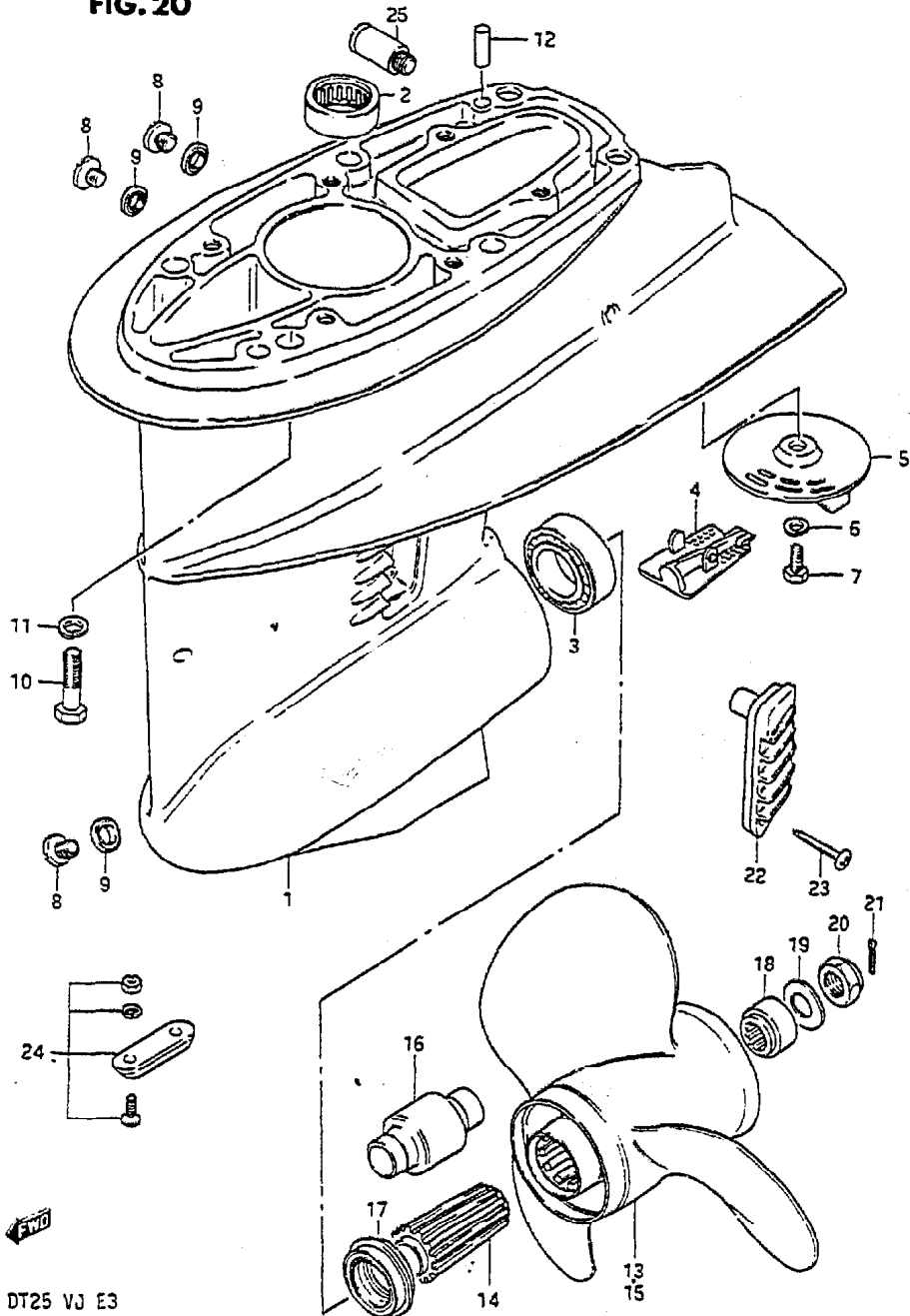

FIG. 20 (D- 9) GEAR CASE

Q'TY

REMARKS

REF.NO.	PART NO.	DESCRIPTION	Q'TY	REMARKS
1	55100-96301-02M	CASE ASSY, gear	1	
2	09263-20046	.BEARING (20.63x26.98x25.4)	1	
3	09265-25015	.BEARING	1	
4	55114-96301	.COVER, gear case	1	
5	55125-96302	TRIM TAB	1	
6	09162-08007	LOCK WASHER	1	
7	09100-08215	BOLT (8x20)	1	
8	09248-10005	PLUG	3	
9	09168-10022	GASKET (10x17x1.5)	3	
10	09100-08224	BOLT (8x35)	6	
11	09162-08007	LOCK WASHER	6	
12	09202-06015	PIN	2	
13-1	58110-96301-01Y	PROPELLER (3x10-1/4x9)	1	P900
13-2	58110-96312-01Y	PROPELLER (3x10-1/4x10)	1	P1000
13-3	58110-96321-01Y	PROPELLER (3x10-1/4x11)	1	P1100
13-4	58110-96331-01Y	PROPELLER (3x10-1/4x12)	1	P1200, L TYPE:STD
13-5	58110-96341-01Y	PROPELLER (3x10-1/4x13)	1	P1300, S TYPE:STD
13-6	58110-96351-01Y	PROPELLER (3x10-1/4x14)	1	P1400
13-7	58110-96361-01Y	PROPELLER (3x10-1/4x15)	1	P1500
14	58120-96313	BUSH	1	
15-1	58100-96400-01Y	PROPELLER (3x10-1/4x9)	1	P901
15-2	58100-96410-01Y	PROPELLER (3x10-1/4x10)	1	P1001
15-3	58100-96420-01Y	PROPELLER (3x10-1/4x11)	1	P1101
15-4	58100-96430-01Y	PROPELLER (3x10-1/4x12)	1	P1201
15-5	58100-96440-01Y	PROPELLER (3x10-1/4x13)	1	P1301
15-6	58100-96450-01Y	PROPELLER (3x10-1/4x14)	1	P1401
15-7	58100-96460-01Y	PROPELLER (3x10-1/4x15)	1	P1501
15-8	58200-96400	PROPELLER (3x10/1/4x13)	1	PS1300,Stainless Steel
16	58120-96400	.BUSH, propeller	1	
17-1	57632-96312	STOPPER, propeller bush	1	for Ref.No.13
17-2	57632-96400	STOPPER, propeller bush	1	for Ref.No.15
18	57633-96300	SPACER	1	

FIG. 20

FIG. 20 (D-10) GEAR CASE

Q'TY

REMARKS

REF.NO.	PART NO.	DESCRIPTION	Q'TY	REMARKS
19	09160-14028	WASHER (14.5x30x2.5)	1	
20	09159-14011	NUT	1	
21	09204-03004	COTTER PIN	1	
22	17631-96310	FILTER, water	2	
23	03142-04259	TAPPING SCREW	2	
24	55300-95500	ZINC ASSY, protection	1	OPT
25	55181-95200	ATTACHMENT, flush hose	1	

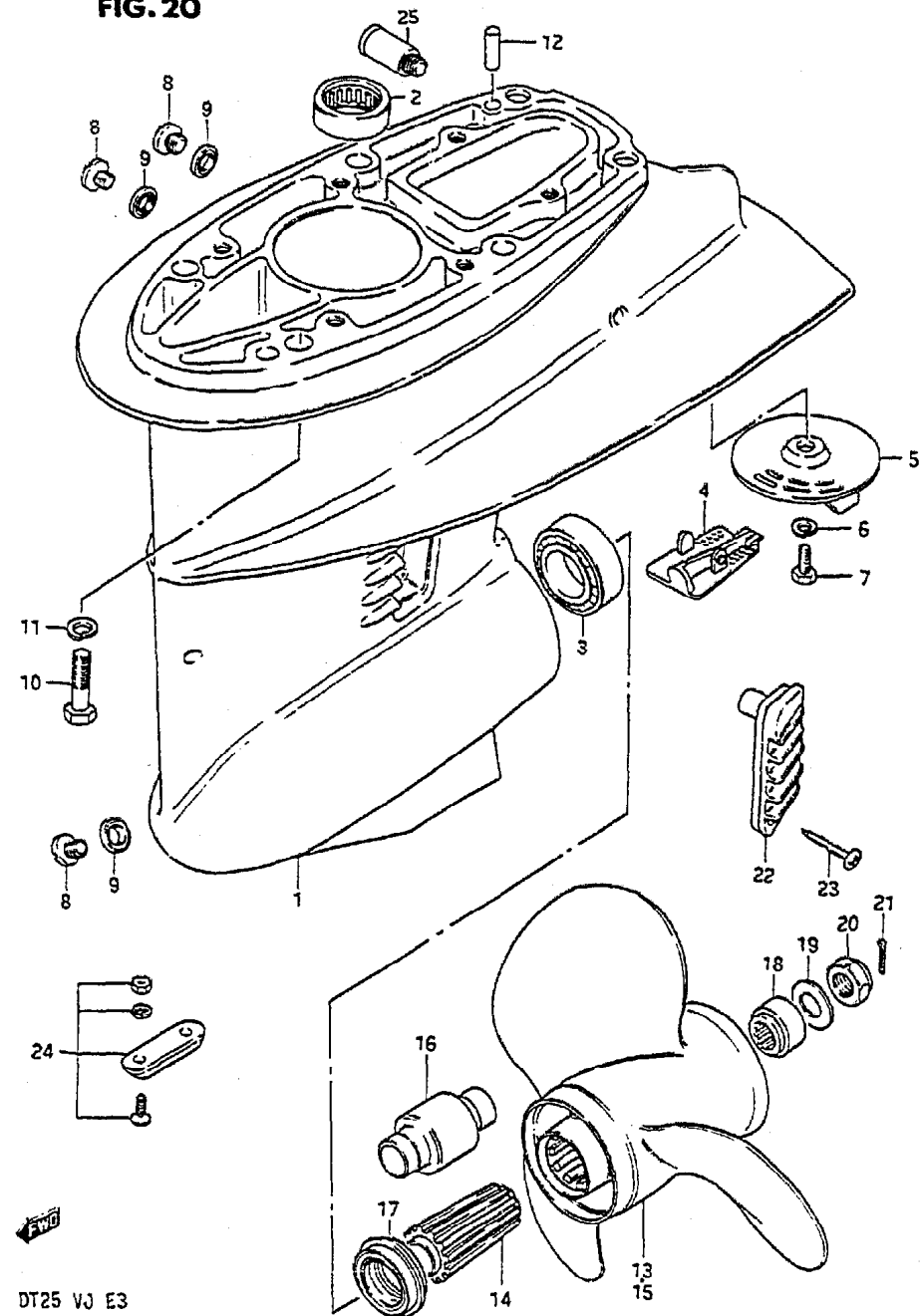

FIG. 21

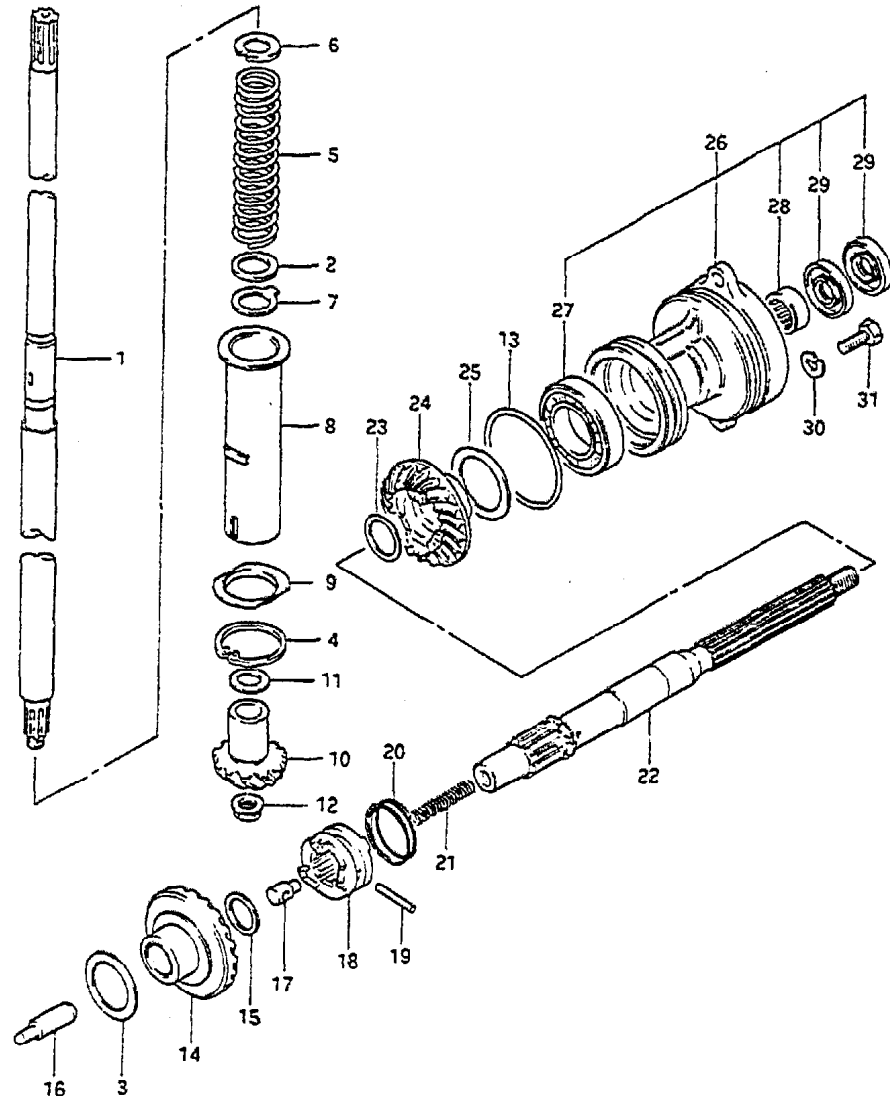

FIG. 21 (D-11) TRANSMISSION

Q'TY

REF.NO.	PART NO.	DESCRIPTION	Q'TY	REMARKS
1-1	57110-96311	SHAFT, drive	1	S TYPE
1-2	57110-96301	SHAFT, drive	1	L TYPE
2	08211-20253	THRUST WASHER	1	
3-1	08221-25366	WASHER (T:0.8)	1	
3-2	09181-25022	WASHER (T:0.9)	1	
3-3	08211-25401	WASHER (T:1.0)	0-1	
3-4	09160-25032	WASHER (T:1.1)	0-1	
3-5	09160-25033	WASHER (T:1.2)	0-1	
3-6	09160-25034	WASHER (T:1.3)	0-1	
3-7	09160-25035	WASHER (T:1.4)	0-1	
3-8	08211-25402	WASHER (T:1.5)	0-1	
4	08331-21409	CIRCLIP	1	
5	09440-25002	SPRING	1	
6	09166-17005	WASHER	1	
7	09167-20021	WASHER	1	
8	57133-96302	SPACER, preload spring	1	
9	57134-96301	BARRIER	1	
10	57311-96310	PYNTON	1	
11-1	09160-15030	WASHER (T:1.7)	0-1	
11-2	09160-15031	WASHER (T:1.8)	0-1	
11-3	09160-15032	WASHER (T:1.9)	0-1	
11-4	08211-15203	WASHER (T:2.0)	0-1	
11-5	09160-15033	WASHER (T:2.1)	0-1	
11-6	08211-15204	WASHER (T:2.2)	0-1	
12	09159-08046	NUT	1	
13	09280-75002	O RING	1	
14	57510-96312	GEAR, foward	1	
15	08211-16242	WASHER (T:1.5)	1	
16	57631-96301	ROD, push	1	
17	09209-08016	PIN	1	
18	57621-96300	SHIFTER, clutch dog	1	
19	09202-05021	PIN	1	
20	09440-35004	SPRING	1	
21	09440-07041	SPRING	1	
22	57610-96303	SHAFT, propeller	1	

FIG. 21

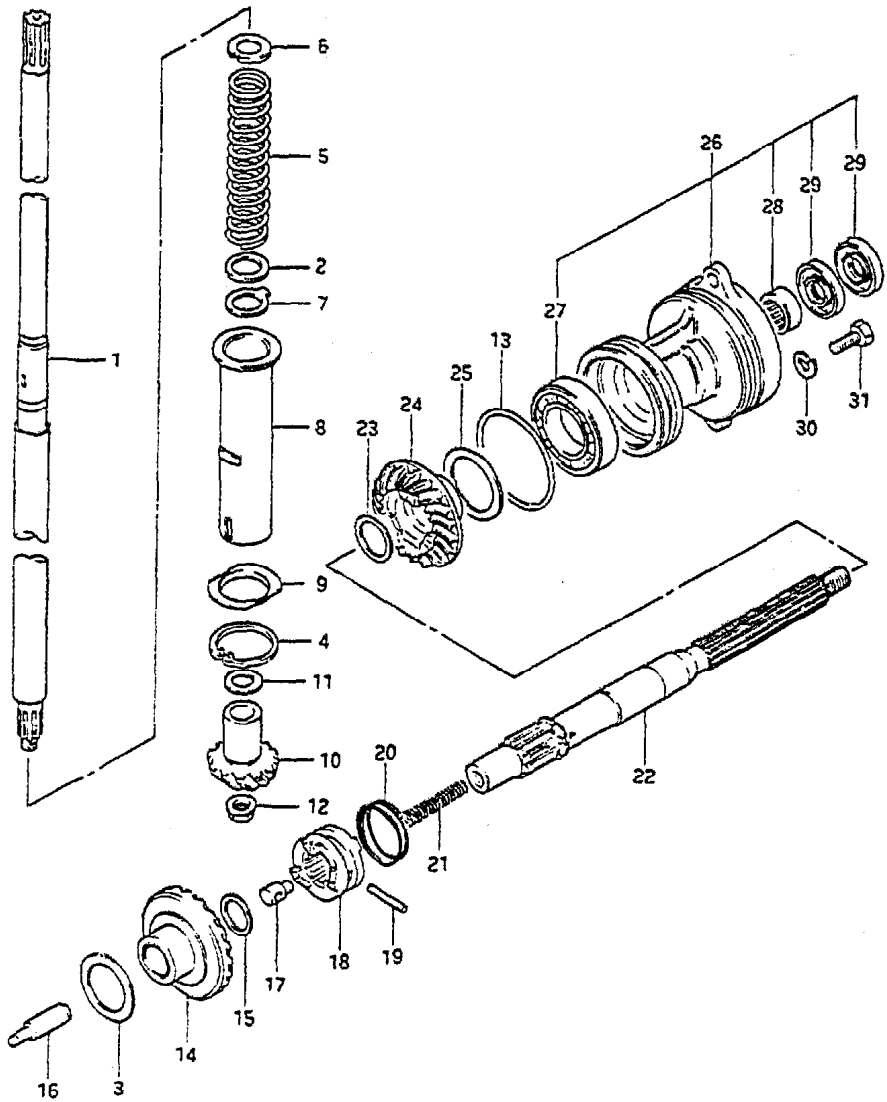
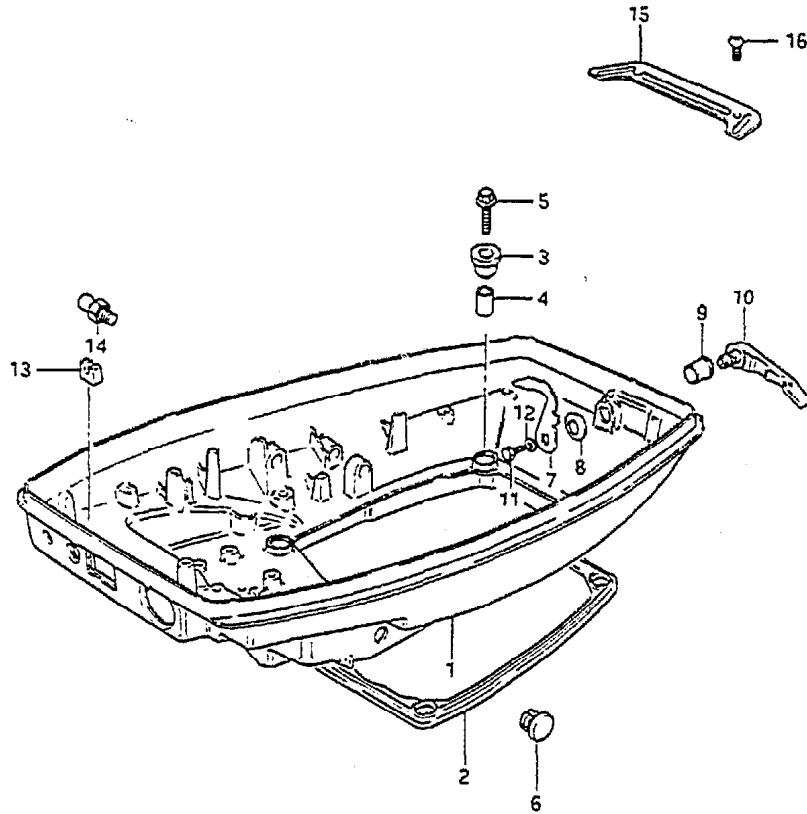

FIG. 21 (D-12) TRANSMISSION

REF.NO.	PART NO.	DESCRIPTION	Q'TY	REMARKS
23-1	08221-20256	WASHER (T:0.8)	0-1	
23-2	09160-20035	WASHER (T:0.9)	0-1	
23-3	08211-20251	WASHER (T:1.0)	0-1	
23-4	09160-20036	WASHER (T:1.1)	0-1	
23-5	09160-20037	WASHER (T:1.2)	0-1	
23-6	09160-20038	WASHER (T:1.3)	0-1	
24	57521-96311	GEAR, reverse	1	
25-1	08211-30401	THRUST WASHER (T:1)	0-1	
25-2	08221-30404	THRUST WASHER (T:0.2)	0-2	
25-3	08221-30405	THRUST WASHER (T:0.5)	0-1	
25-4	08221-30406	THRUST WASHER (T:0.8)	0-1	
26	56120-96311-02M	HOUSING, propeller shaft brg	1	
27	08113-60060	.BEARING	1	
28	09263-20047	.BEARING (20x26x20)	1	
29	09289-20009	.OIL SEAL (20x34x6.5)	2	
30	09162-06006	LOCK WASHER	2	
31	09100-06136	BOLT	2	

FIG. 22

FIG. 22 (E- 2) UNDER COVER



Q'TY

REMARKS

REF.NO.	PART NO.	DESCRIPTION	Q'TY	REMARKS
1	61110-96304-02M	COVER, engine under	1	
2	61113-96300	SEAL, under cover	1	
3	09320-10031	CUSHION, under cover	4	
4	09180-06112	SPACER (6.8x10x11.5)	4	
5	09103-06094	BOLT (6x25)	4	
6	09250-08007	CAP, cushion	2	
7-1	61631-96301	HOOK, under cover	1	model VG,VH
7-2	61631-94410	HOOK, under cover	1	model VJ
8	09164-13005	WASHER	1	
9	09306-13002	BUSH	1	
10	61633-96002-02M	LEVER, hook	1	
11	01107-06102	BOLT	1	
12	08322-21062	WASHER	1	
13	13625-94300	CAP	1	
14	22511-99001	NIPPLE, clutch notch	1	
15	61138-96301	COVER, water	1	
16	09125-06069	SCREW	2	

FWO

FIG. 23

FIG. 23 (E- 3) ENGINE COVER

Q'TY

REF.NO.	PART NO.	DESCRIPTION	Q'TY	REMARKS
1-1	61401-96830-02M	COVER SET, engine	1	model VG,VH
1-2	61401-96831-02M	COVER SET, engine	1	model VJ
2	61431-96301-02M	.HANDLE, tilt up	1	
3	03242-06169	.SCREW	3	
4	61422-93930-70G	.MARK, emblem, front	1	
5	61443-96380-26G	.DECAL, side SYBD	1	
6	61453-96380-26G	.DECAL, side PORT	1	
7	61435-96380-70G	.EMBLEM, rear	1	
8	21131-96003	.MARK, clutch shift	1	
9	61441-96310	.EMBLEM, side	2	
10-1	61610-96302	.FASTENER	1	model VG,VH
10-2	61610-96310	.FASTENER	1	model VJ
11	01107-06122	.BOLT	1	
12	08321-21062	.LOCK WASHER	1	
13	08322-21062	.WASHER	1	
14	61112-96302	RUBBER, under cover	1	
15	61622-96301	SEAL, rubber, recoil starter	1	
16	68110-95210	COVER, weather	1	OPT
17	09800-81800	TOOL SET	1	

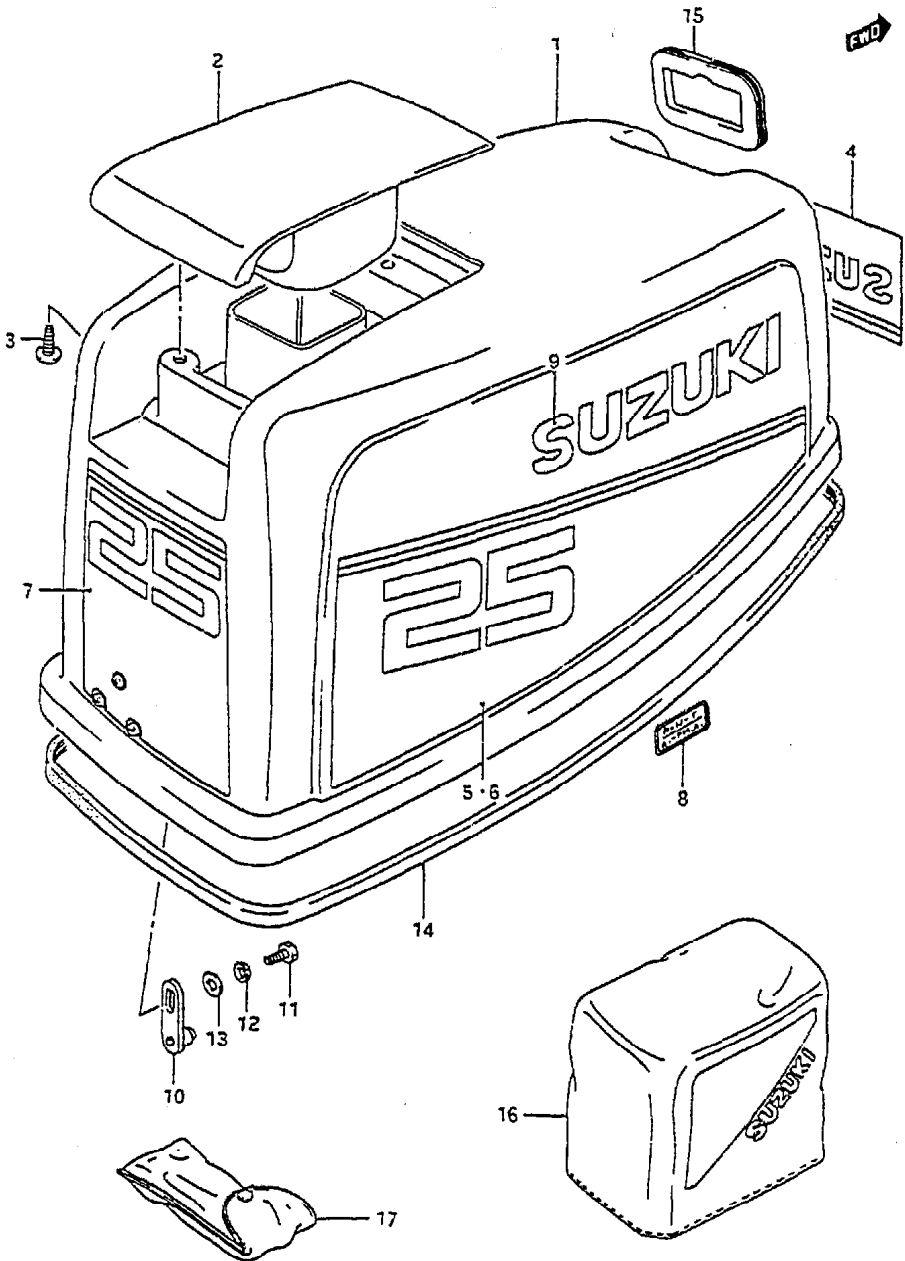

FIG. 24

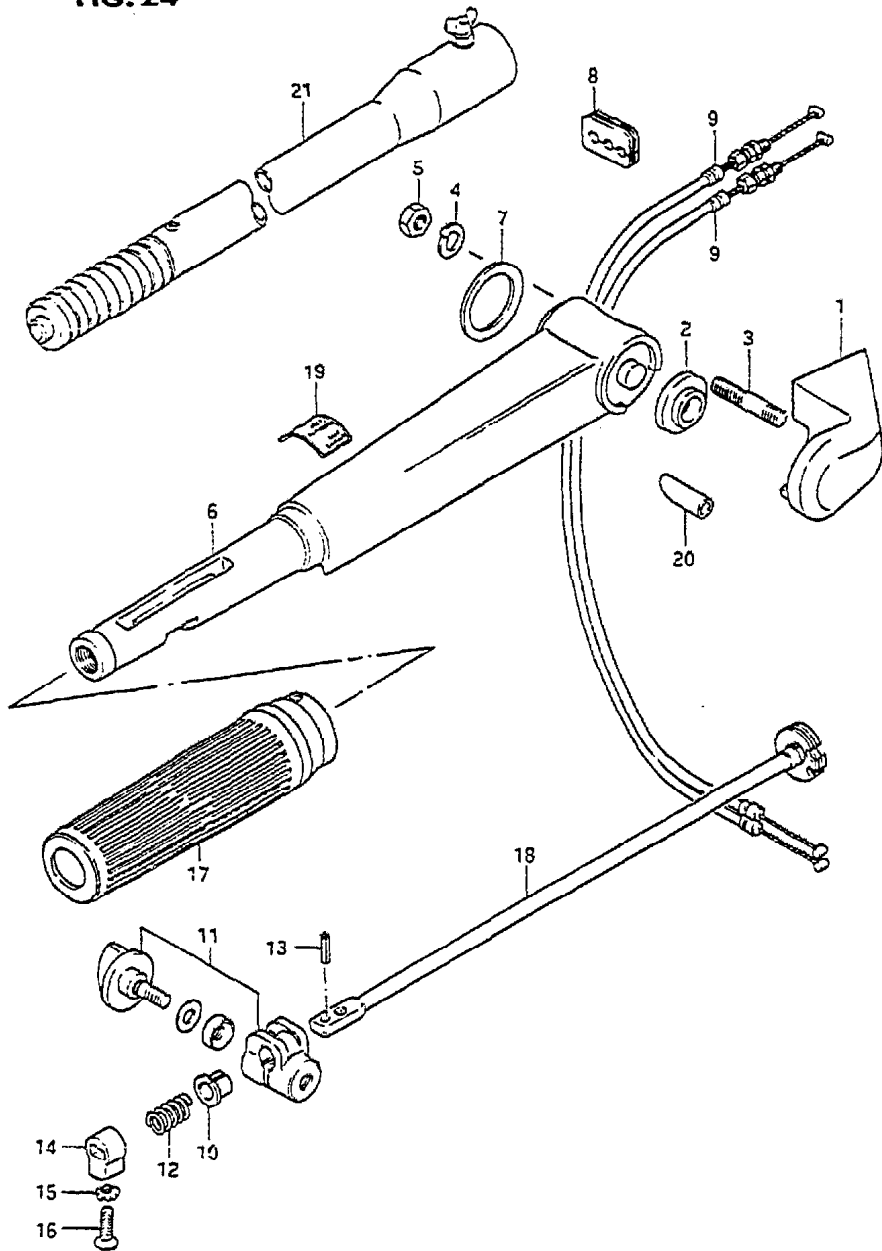

FIG. 24 (E- 4) HANDLE

Q'TY

REF.NO.	PART NO.	DESCRIPTION	Q'TY	REMARKS
1	63121-96302-02M	COVER, tiller handle	1	
2	63114-94300	SPACER, handle cover	1	
3	09108-08147	STUD BOLT	2	
4	09162-08007	LOCK WASHER	2	
5	09140-08016	NUT	2	
6	63111-96311-02M	HANDLE, tiller	1	
7	63115-96301	SPACER	1	
8	63625-96300	GROMMET	1	
9	63610-96301	CABLE, throttle	2	
10	63225-93200	BUSH, handle rod	1	
11	63240-96300	ADJUSTER, handle grip	1	
12	09440-12027	SPRING	1	
13	63227-93200	PIN, handle rod	1	L:14
14	63223-93201	STOPPER, handle rod	1	
15	09163-06001	LOCK WASHER	1	
16	09126-06006	SCREW	1	
17	63210-93901	GRIP, handle	1	
18	63220-96300	ROD, handle	1	
19	63215-93400	MARK, handle	1	
20	63117-96300	COVER, stop switch wire	1	
21	63300-93900	BAR ASSY, extension	1	OPT

FIG. 25

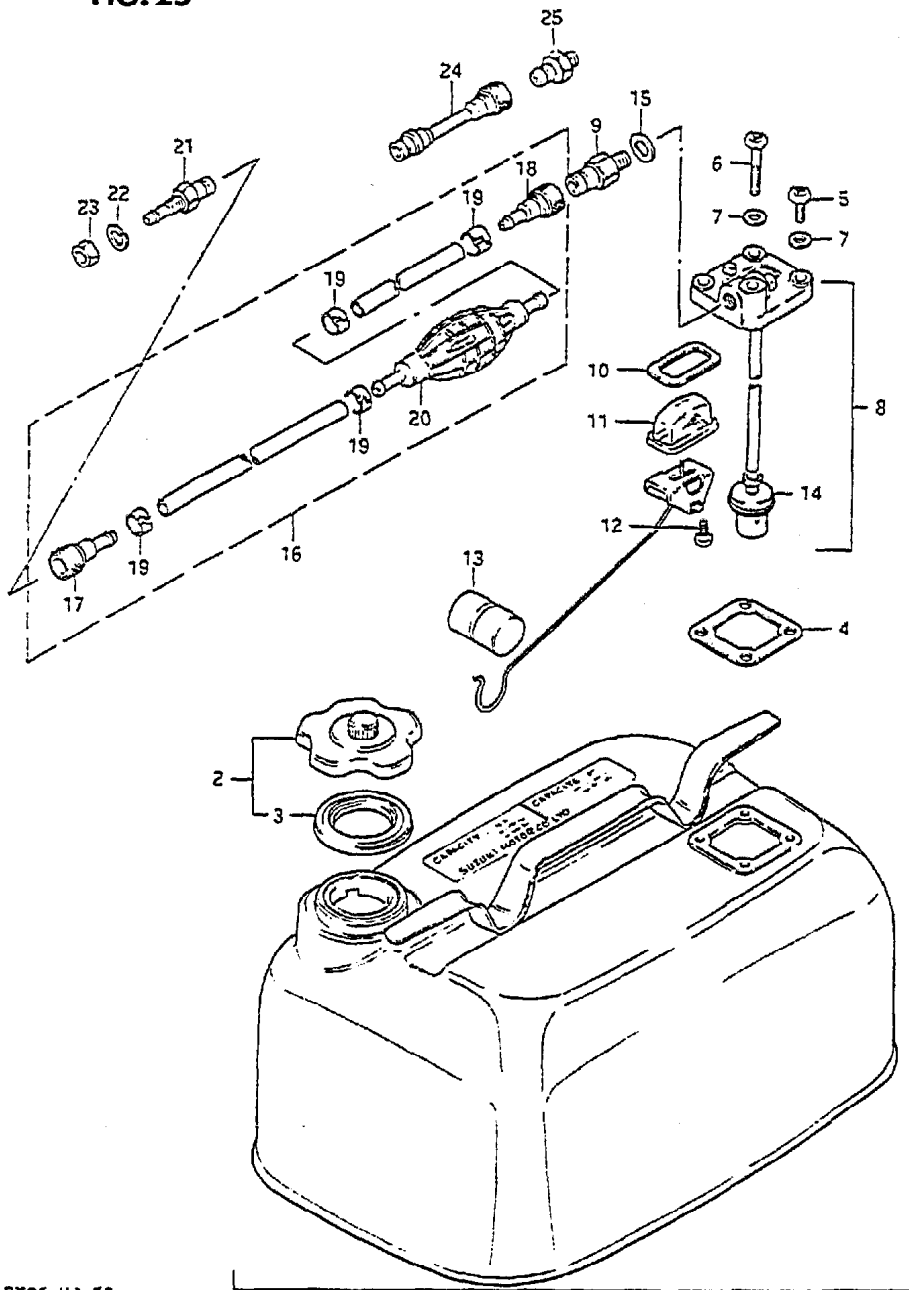

FIG. 25 (E- 5) FUEL TANK (MODEL VG, VH)

Q'TY

REF.NO.	PART NO.	DESCRIPTION	Q'TY	REMARKS
1	65000-95201	TANK SEY, fuel (23L)	1	6 US.GAL./ 5 IMP.GAL.
2	65510-98507	.CAP ASSY	1	
3	65561-98502	.GASKET	1	
4	65871-93010	.GASKET, fuel gauge	1	
5	02112-06162	.SCREW	3	
6	02112-06402	.SCREW	1	
7	09168-06002	.WASHER	4	
8	65850-95506	.GAUGE ASSY, fuel	1	
9	65740-95500	..CONNECTOR, male fuel	1	M12,00:13
10	65854-93001	..GASKET, strainer	1	
11	65853-93001	..STRAINER	1	
12	02112-04108	..SCREW	2	
13	65864-95200	..FLOAT	1	
14	65830-95500	..FILTER, outlet	1	
15	09168-12001	..GASKET (12.5x20x1)	1	
16	65700-95206	HOSE, fuel	1	
17	65750-98505	.CONNECTOR, female fuel	1	ID:11
18	65750-93000	.CONNECTOR, female fuel	1	ID:13
19	65781-98500	.CLIP	4	
20	65770-99703	.PUMP, squeeze	1	
21	65720-98520	CONNECTOR, male fuel	1	00:11
22	08321-21102	LOCK WASHER	1	
23	08310-22102	NUT	1	
24	65700-95271	HOSE, fuel joint	1	OPT
25	65720-98590	CONNECTOR, male fuel	1	OPT,M12-11

Refer to FIG.26 (E-6) for FUEL TANK (MODEL VJ)

FIG. 26

FIG. 26 (E- 6) FUEL TANK (MODEL VJ)

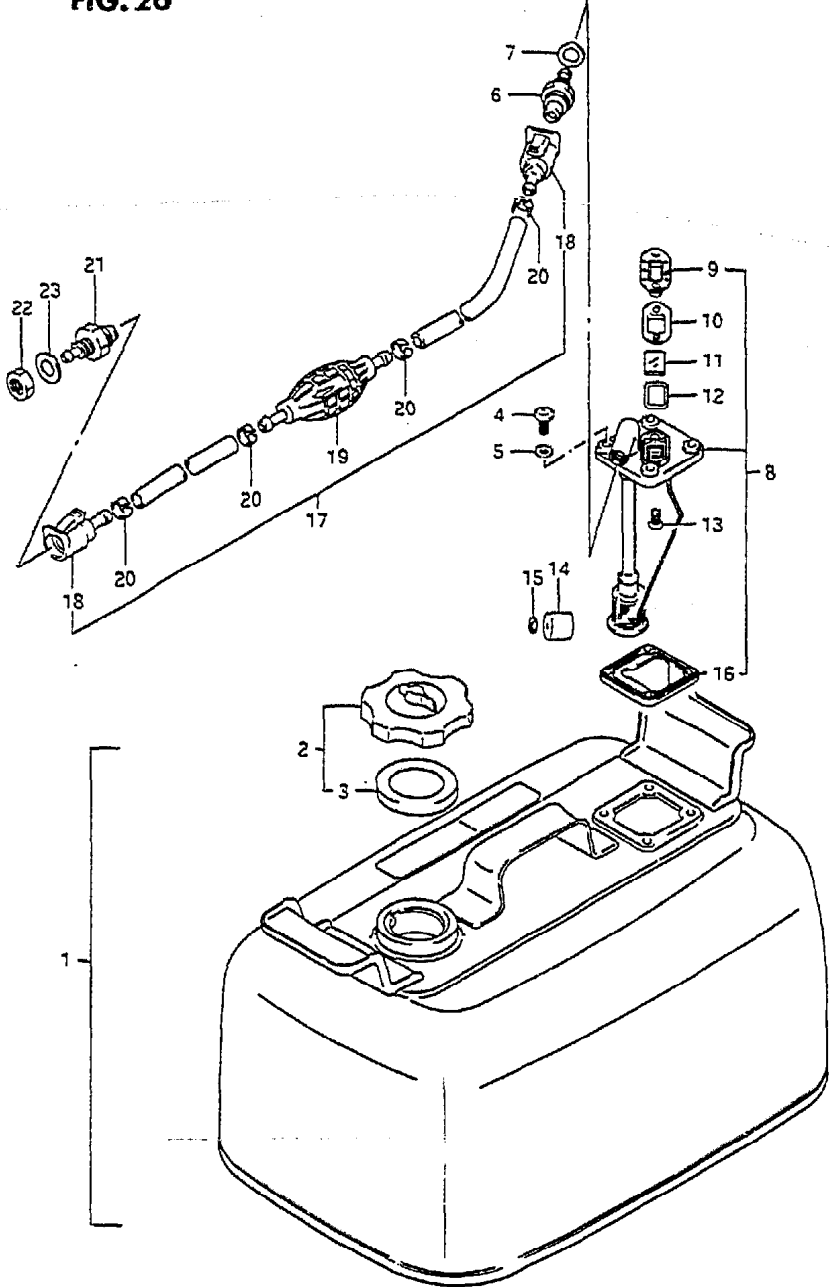

REF. NO.	PART NO.	DESCRIPTION	Q'TY	REMARKS
1	65800-92820	TANK SET, fuel (24L)	1	6.3 U.S GAL/5.3 IMP GAL
2	65510-92000	.CAP ASSY, separate tank	1	
3	65561-92000	..GASKET, tank cap	1	
4	02152-06162	.SCREW	4	
5	09168-06002	.WASHER	4	
6	65720-94410	.CONNECTOR, fuel	1	
7	09168-12001	.GASKET, connector	1	
8	65850-92000	.GAUGE ASSY, fuel	1	
9	65855-92000	..COVER, gauge	1	
10	65854-92010	..GASKET	1	
11	65853-92000	..LENS	1	
12	65854-92000	..GASKET, lens	1	
13	03221-04086	..SCREW	2	
14	65864-92000	..FLDPT	1	
15	65866-92000	..NUT, push	1	
16	65871-92000	..GASKET, fuel	1	
17	65700-87015	HOSE, fuel	1	
18	65750-94403	.CONNECTOR, fuel	2	
19	65770-95503	.PUMP, squeeze	1	
20	65781-98500	.CLIP	4	
21	65720-94400	CONNECTOR, fuel	1	
22	08310-22102	NUT	1	
23	08321-21102	LOCK WASHER	1	

FIG. 27

FIG. 27 (F- 2) OPTIONAL : ELECTRICAL (FOR MANUAL STARTER)
Q'TY

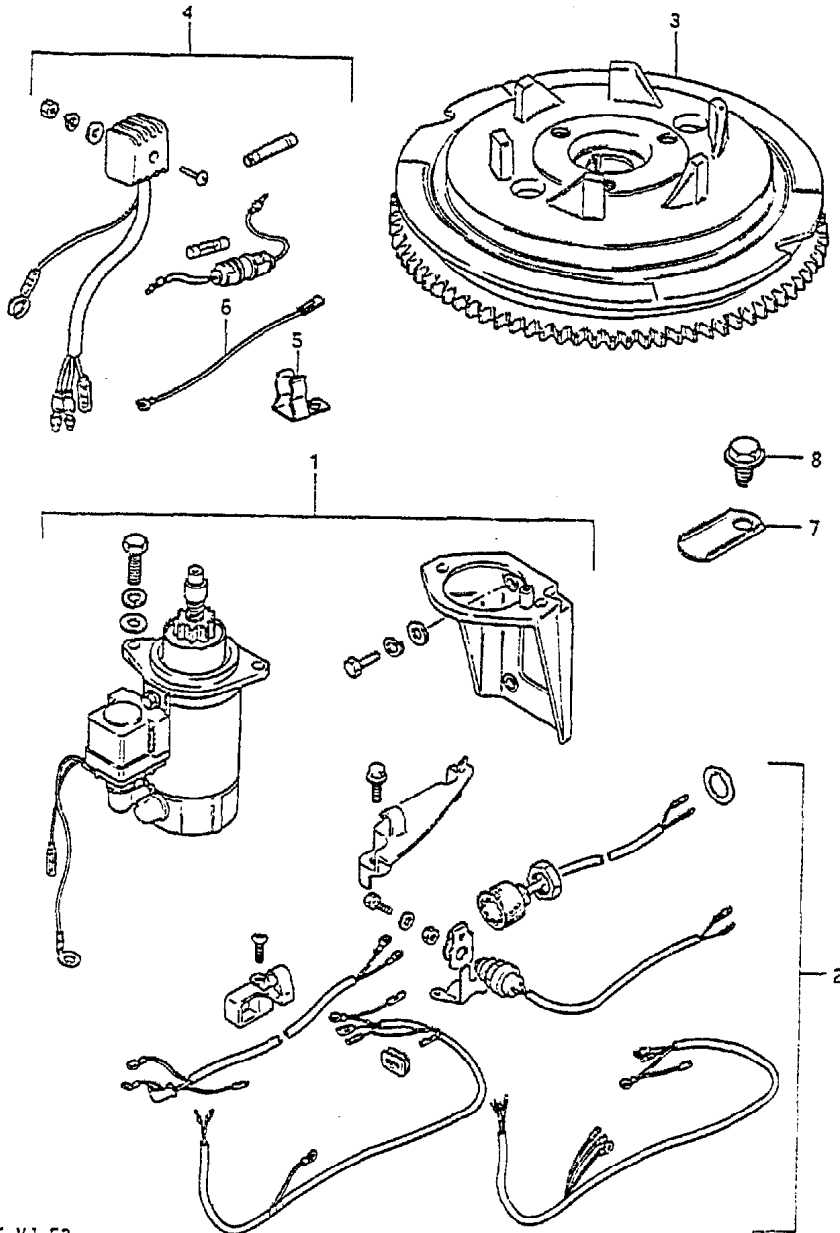

REF.NO.	PART NO.	DESCRIPTION	Q'TY	REMARKS
1	31101-96300	MOTOR SET, starter	1	
2	33800-96301	SWITCH, starter/cable set	1	
3	32102-96380	FLYWHEEL	1	
4	32801-96300	RECTIFIER SET	1	
5	36791-95200	.HOLDER	1	
6	36898-93300	.LEAD, wire	1	
7	33815-94500	PROTECTOR, cable	1	
8	09103-06049	BOLT (6x12)	1	

FIG. 28

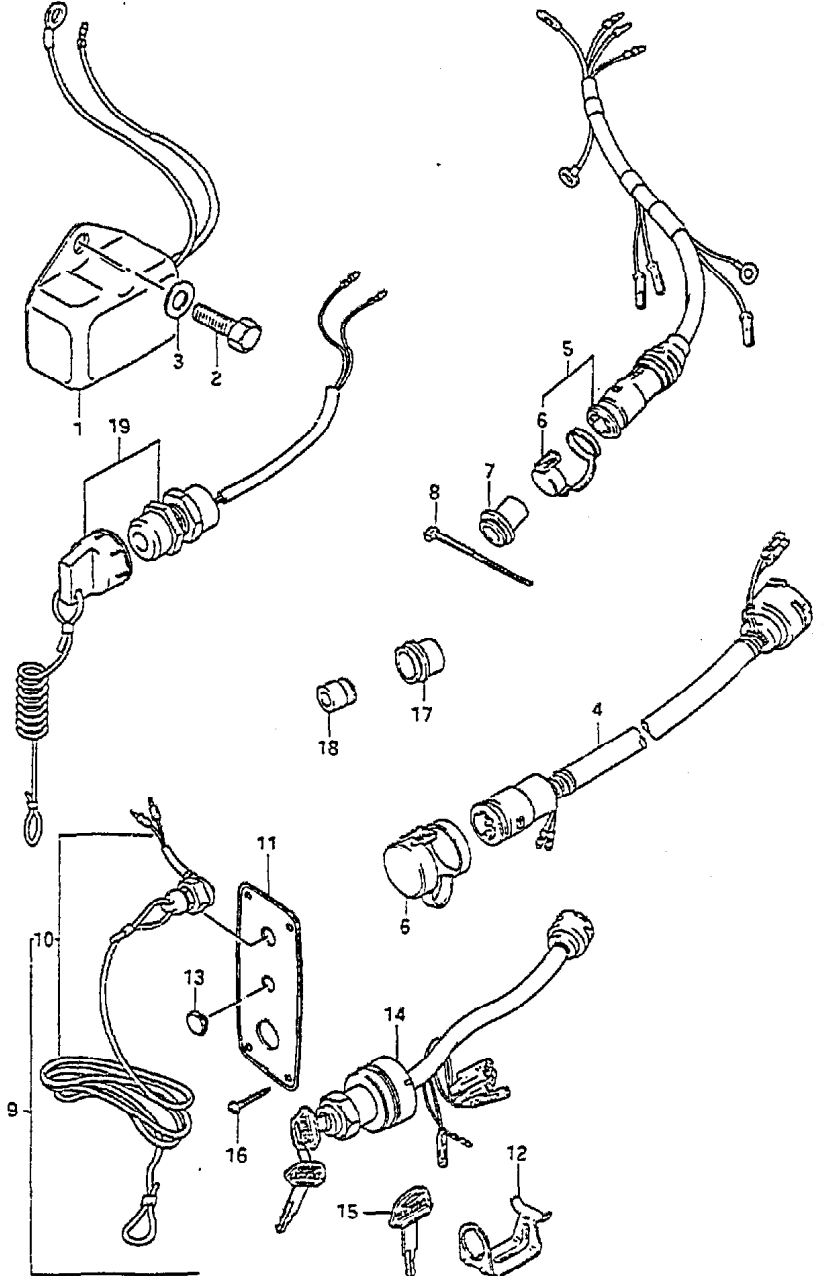

FIG.28 (F- 3) OPTIONAL : ELECTRICAL (FOR ELECTRIC STARTER)

REF.NO.	PART NO.	DESCRIPTION	Q'TY	REMARKS
1	32500-95722	REGULATOR, voltage	1	
2	01107-06128	BOLT	2	
3	08322-21067	WASHER	2	
4	36620-87020	WIRING HARNESS, extension	1	
5	36630-96330	WIRING HARNESS, remo-con	1	
6	36631-94300	.CAP, remo-con harness	1	
7	36639-94300	GROMMET	1	
8	36632-95501	CLAMP, connector grommet	1	
9	37100-95210	PANEL ASSY, switch	1	
10	37820-95353	.SWITCH ASSY, emergency	1	
11	37139-95251	.PANEL, switch	1	
12	37150-93350	.HOLDER	1	H27.1
13	37101-93310	.CAP, panel	2	
14	37110-95210	.SWITCH, emergency	1	
15-1	37141-93300	..KEY, spare (8511)	1	
15-2	37141-93310	..KEY, spare (8512)	1	
15-3	37141-93320	..KEY, spare (8513)	1	
15-4	37141-93330	..KEY, spare (8611)	1	
15-5	37141-93340	..KEY, spare (8612)	1	
15-6	37141-93350	..KEY, spare (8613)	1	
16	03112-04129	SCREW	4	
17	36612-94301	GROMMET, 1	1	
18	36613-94300	GROMMET, 2	1	
19	37820-94420	SWITCH ASSY, emergency	1	

FIG. 29

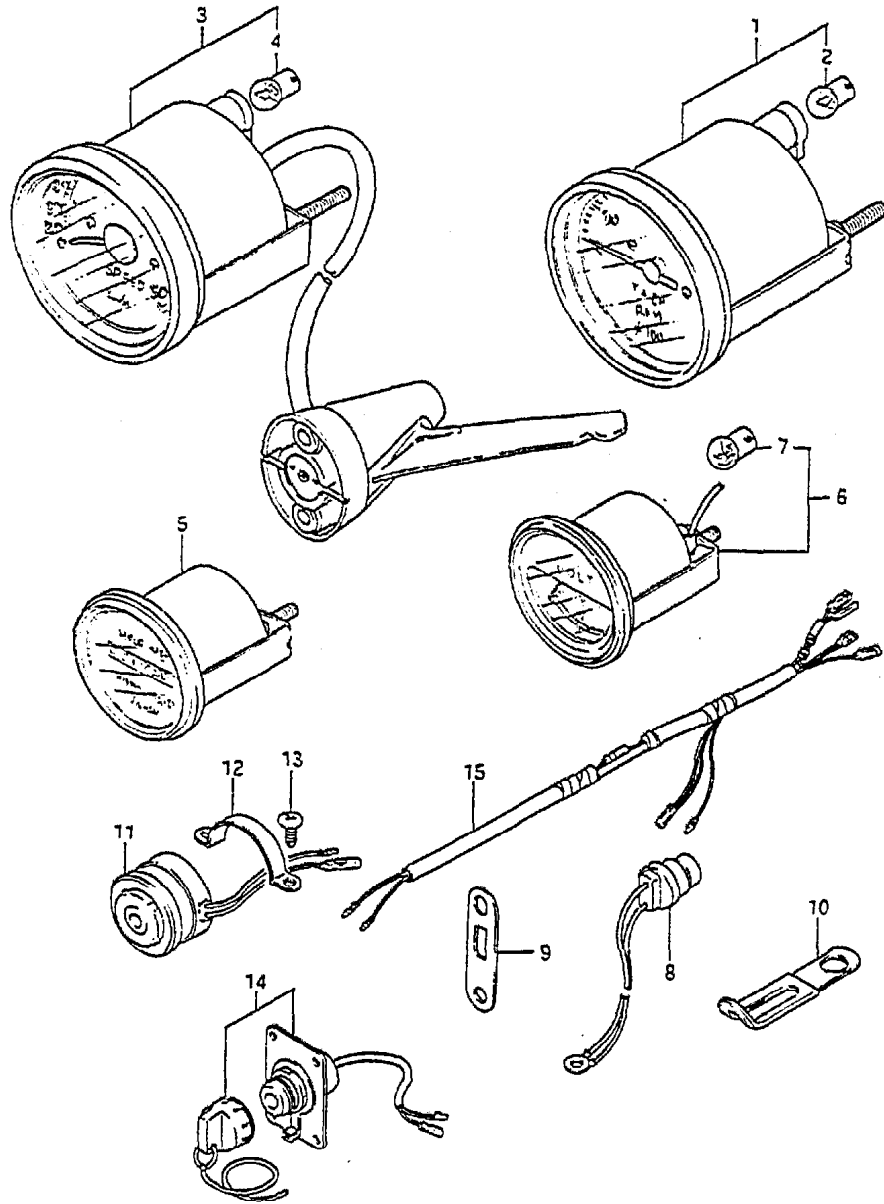

FIG.29 (F- 4) OPTIONAL : ELECTRICAL

Q'TY

REF.NO.	PART NO.	DESCRIPTION	Q'TY	REMARKS
1	34200-95512	TACHOMETER ASSY	1	
2	09471-12001	.BULB (12V,3.4W)	1	
3	34100-95502	SPEEDOMETER ASSY	1	
4	09471-12001	.BULB (12V,3.4W)	1	
5-1	34500-95502	METER ASSY, hour	1	
5-2	34500-95510	METER ASSY, hour	1	QUARTZ
6	34600-95504	METER ASSY, voltage	1	
7	09471-12001	.BULB (12V,3.4W)	1	
8	34850-94700	SWITCH, heat	1	
9	34853-94301	SUPPORTER, unit	1	
10	09404-08201	CLAMP (L:52)	1	
11	38500-95503	BUZZER, warning	1	
12	38501-95500	BAND, warning buzzer	1	
13	02112-05088	SCREW	2	
14	34108-94500	SWITCH ASSY, meter	1	
15	34109-94500	LEAD, meter extension	1	

FIG. 30

FIG.30 (F- 5) OPTIONAL : ELECTRICAL (FOR MANUAL STARTER)

REF.NO.	PART NO.	DESCRIPTION	Q'TY	REMARKS
1	52500-95722	REGULATOR, voltage	1	
2	01107-06128	BOLT	2	
3	08322-21067	WASHER	2	
4	39600-93900	CONSENT SET	1	
5	36632-95501	.CLAMP	1	
6	39601-93902	.CONSENT ASSY, lamp	1	
7	39602-93900	.PLUG ASSY, lamp cord	1	
8	39603-93900	.GROMMET	1	

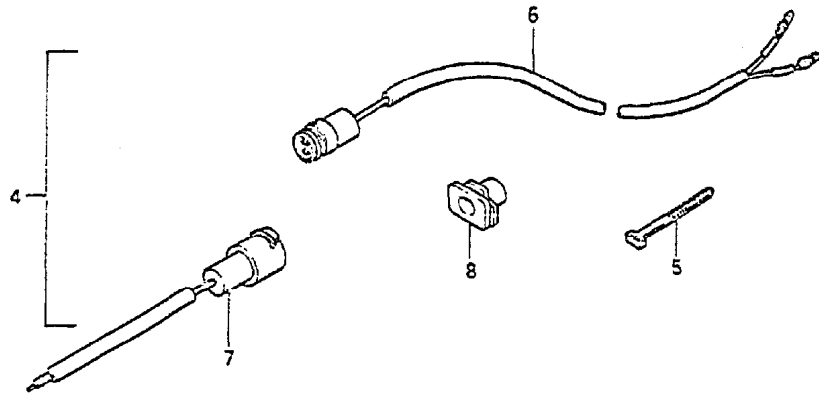
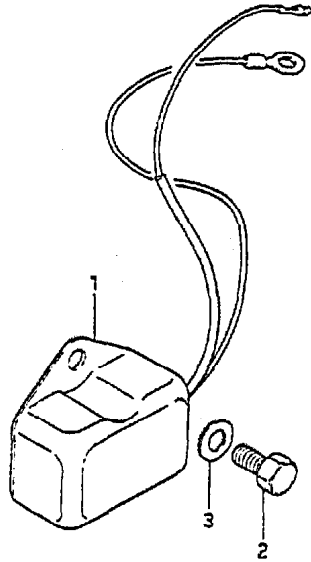

FIG.31

FIG.31 (F- 6) OPTIONAL : REMOTE CONTROL PARTS

Q'TY

REF.NO.	PART NO.	DESCRIPTION	REMARKS
1	67130-94302-02M	REMOTE CONTROL PARTS ASSY	1
2	67341-94301	.HOLDER, remo-con cable	2
3	67440-93701	.GUIDE, clutch cable	1
4	09205-02006	..SPRING PIN	1
5	09440-09012	..SPRING	1
6	09160-06015	.WASHER (6.5x13x1)	2
7	09100-06115	.BOLT (6x15)	2
8	67466-95200	.CONNECTOR, remo-con cable	1
9	67414-94301-02M	.LEVER, remo-con throttle	1
10	09100-06115	.BOLT (6x15)	1
11	09160-06015	.WASHER (6.5x13x1)	1
12	09119-06047	.BALL PIVOT	1
13-1	67320-95500	CABLE ASSY, remocon 6F (1.8M)	2
13-2	67320-95510	CABLE ASSY, remocon 7F (2.1M)	2
13-3	67320-95520	CABLE ASSY, remocon 8F (2.4M)	2
13-4	67320-95530	CABLE ASSY, remocon 9F (2.7M)	2
13-5	67320-95540	CABLE ASSY, remocon 10F (3.1M)	2
13-6	67320-95550	CABLE ASSY, remocon 11F (3.4M)	2
13-7	67320-95560	CABLE ASSY, remocon 12F (3.7M)	2
13-8	67320-95570	CABLE ASSY, remocon 13F (4.0M)	2
13-9	67320-95580	CABLE ASSY, remocon 14F (4.3M)	2
13-10	67320-95590	CABLE ASSY, remocon 15F (4.6M)	2
13-11	67320-95600	CABLE ASSY, remocon 16F (4.9M)	2
13-12	67320-95610	CABLE ASSY, remocon 17F (5.2M)	2
13-13	67320-95620	CABLE ASSY, remocon 18F (5.5M)	2
13-14	67320-95630	CABLE ASSY, remocon 19F (5.8M)	2
13-15	67320-95640	CABLE ASSY, remocon 20F (6.1M)	2
13-16	67320-95650	CABLE ASSY, remocon 22F (6.7M)	2
14	67200-95203	BOX ASSY, remocon STBD	1
15	67200-95213	BOX ASSY, remocon PORT	1
16	67200-95871	BOX ASSY, twin remocon	1

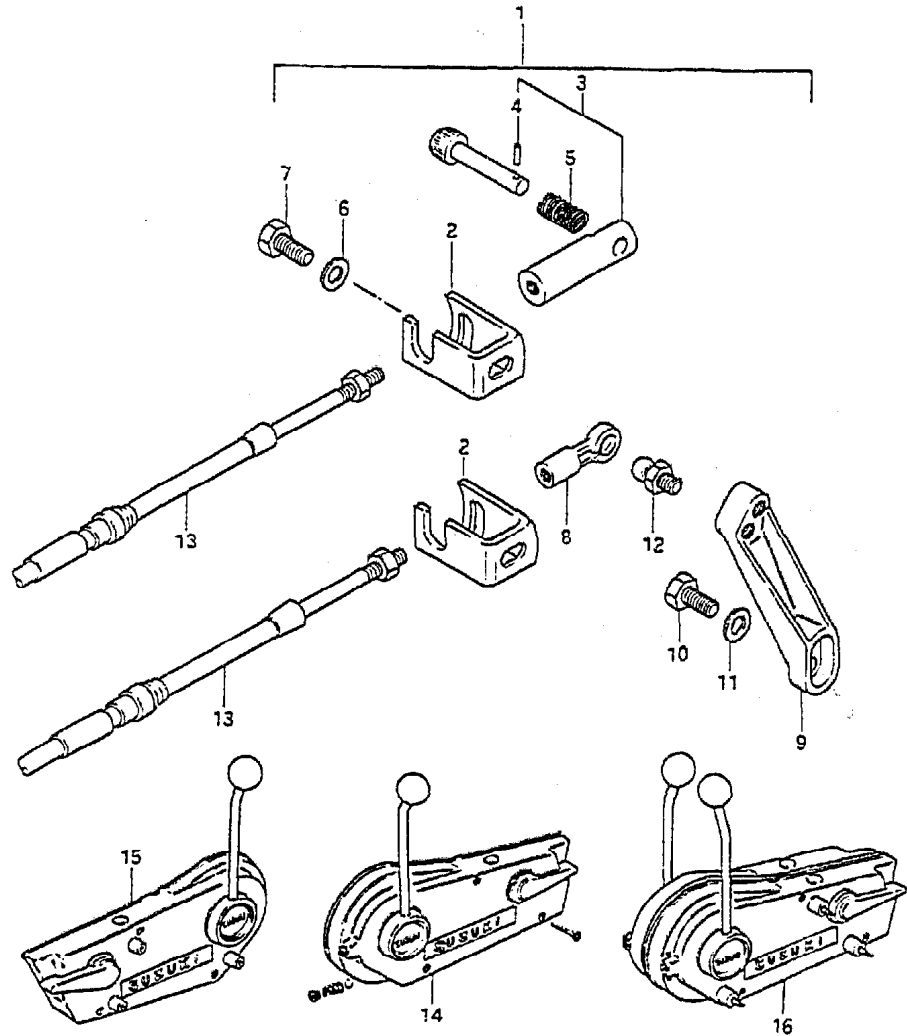

FIG.32

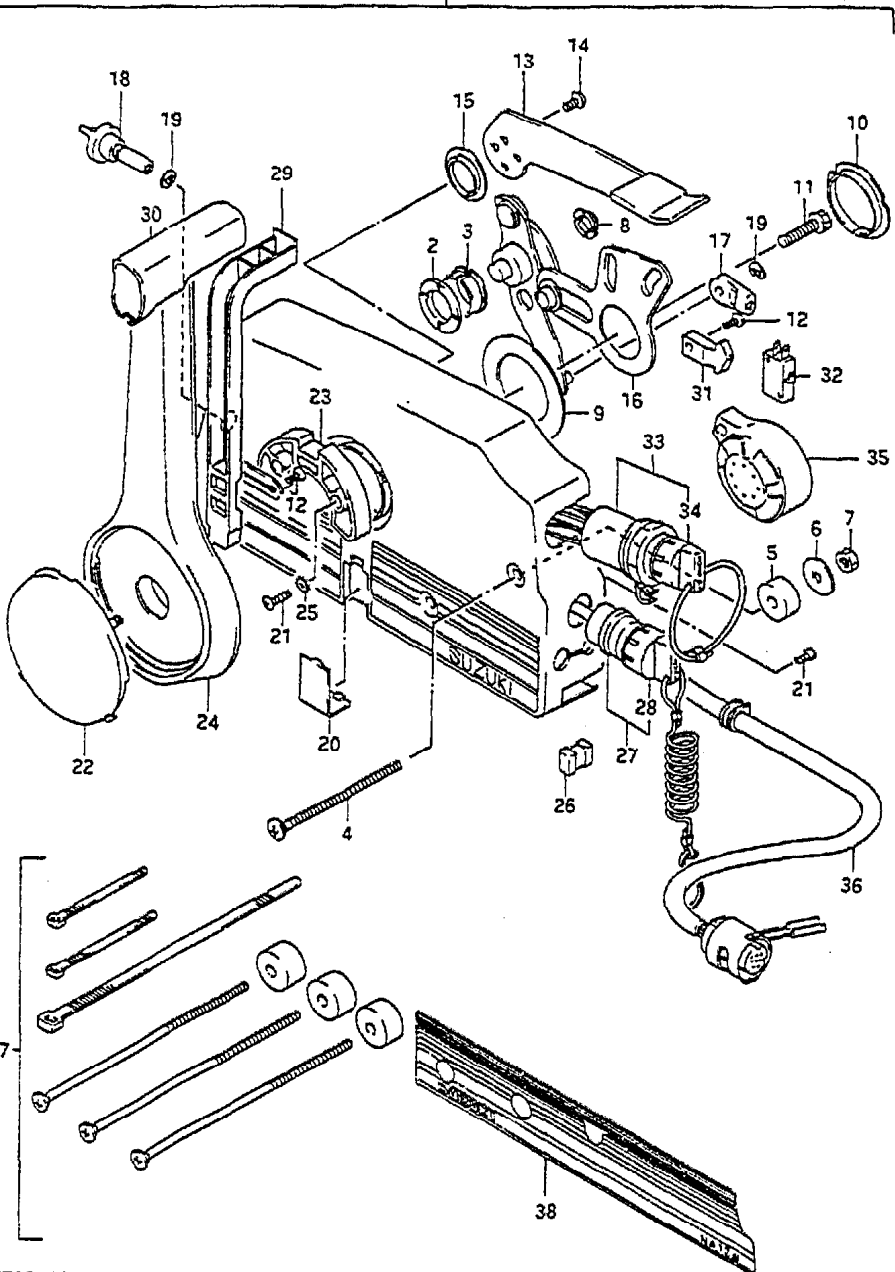

FIG.32 (F- 7) OPTIONAL : REMOTE CONTROL

REF.NO.	PART NO.	DESCRIPTION	Q'TY	REMARKS
1-1	67200-94610-02M	REMOTE CONTROL BOX ASSY	1	model VG,VH with ELECTRIC START PARTS
1-2	67200-94630-02M	REMOTE CONTROL BOX ASSY	1	model VJ with ELECTRIC START PARTS
1-3	67200-93960	REMOTE CONTROL BOX ASSY	1	SHIFT AND THROTTLE ONLY
2	67232-95600	.BUSH	1	
3	67232-95620	.BUSH	1	
4	67296-95600	.SCREW	3	
5	67294-95600	.SPACER	3	
6	67288-94310	.WASHER	3	
7	09140-06004	.NUT	3	
8	67232-95610	.BUSH	2	
9	67253-95600	.WASHER	1	
10	67252-95600	.BUSH	2	
11	09100-08112	.BOLT	1	
12-1	67296-94300	.SCREW	3	INC. 67200-94610-02M, 67200-94630-02M
12-2	67296-94300	.SCREW	2	INC. 67200-93960
13	67241-95650	.LEVER, free throt	1	
14	09126-05003	.SCREW	2	
15	67243-95600	.BUSH	1	
16	67220-95600	.PLATE ASSY	1	
17	67275-95600	.END, cable	2	
18	67223-95600	.KNOB, brake ADJ	1	
19	67292-94300	.E RING	3	
20	67267-95610	.COVER, wire	1	
21	67296-95610	.SCREW	7	
22	67257-95610	.CAP, lever	1	
23	67256-95600	.HOLDER, neut lock	1	
24	67251-95650	.LEVER, handle	1	

* 67200-93960 includes Ref.No.2-30

FIG. 32

FIG.32 (F- 8) OPTIONAL : REMOTE CONTROL

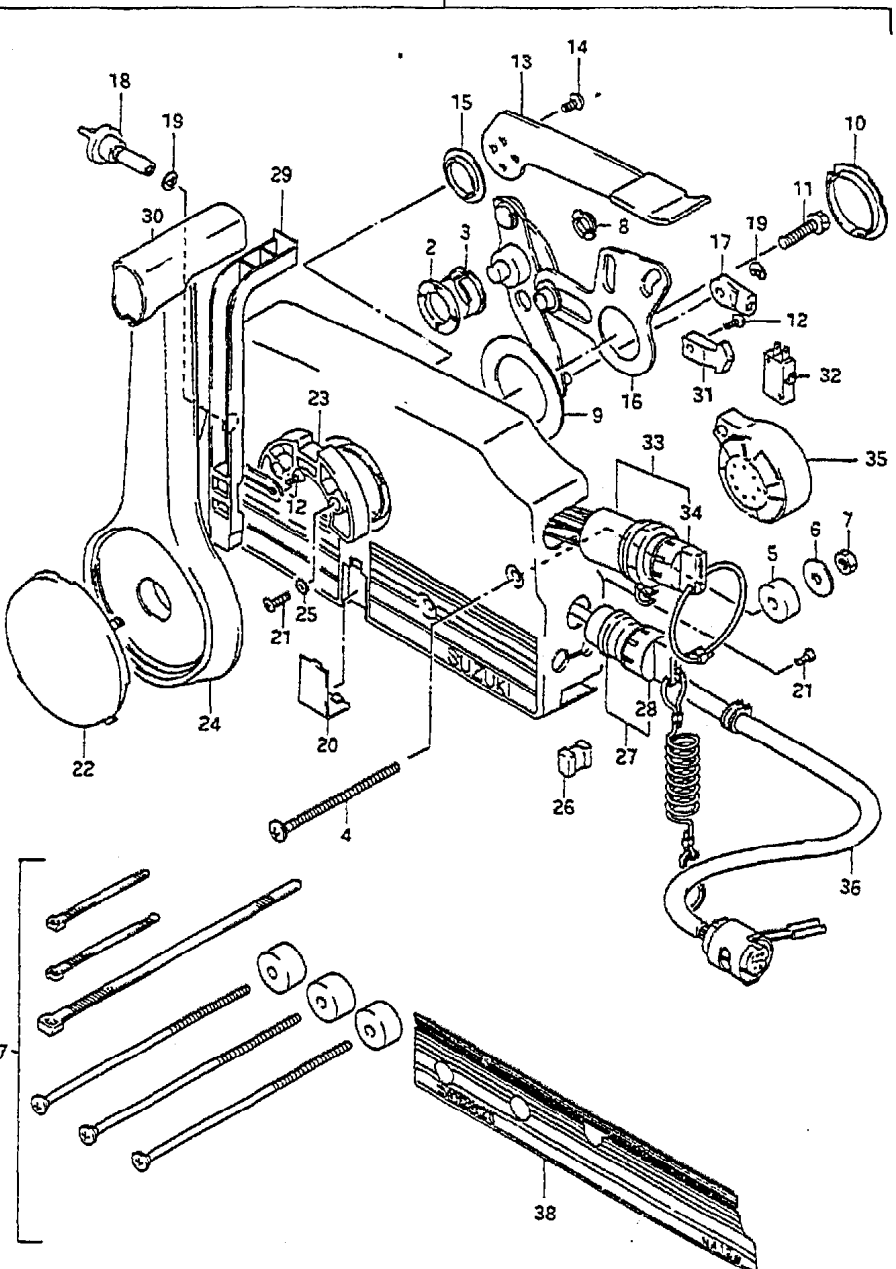

REF.NO.	PART NO.	DESCRIPTION	Q'TY	REMARKS
25	67297-95600	.WASHER	2	
26	67273-95600	.SPACER	1	
27	37820-94402	.SWITCH ASSY, emergency	1	
28	37823-94400	..CAP & ROPE	1	
29	67255-95600	.ARM, neutral lock	1	
30	67261-95610	.GRIP	1	
31	67214-95600	.ACTUATOR	1	INC. 67200-94610-02M, 67200-94630-02M
32	37721-94600	.SWITCH, neutral	1	
33	37110-94600	.IGNITION SWITCH	1	
34-1	37141-94400	..KEY (101)	1	
34-2	37141-94410	..KEY (102)	1	
34-3	37141-94420	..KEY (103)	1	
34-4	37141-94430	..KEY (104)	1	
34-5	37141-94440	..KEY (105)	1	
34-6	37141-94450	..KEY (106)	1	
35-1	38500-87000	.BUZZER	1	model VG, VH
35-2	38500-87010	.BUZZER	1	model VJ
36	36620-94610	.WIRING HARNESS 7 WIRES	1	
37	67140-95600	ATTACHMENT, twin remo-con kit	1	
38	67282-95610	DECAL, remocon box PORT	1	Black

FIG. 33

FIG.33 (F- 9) OPTIONAL : DRAG LINK

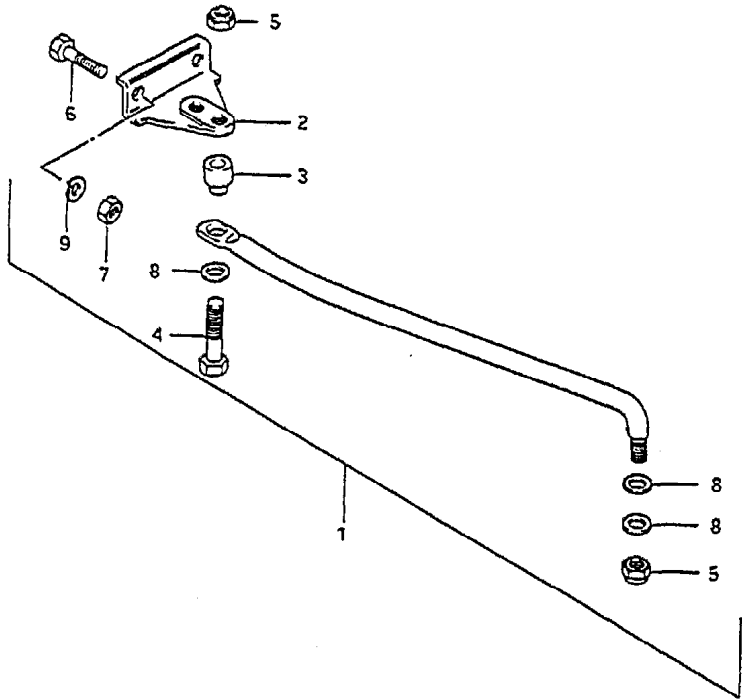

REF.NO.	PART NO.	DESCRIPTION	Q'TY	REMARKS
1	67701-96300	DRAG LINK ASSY	1	
2	43755-96301	.ATTACHMENT, steering BRKT	1	
3	67721-94300	.SPACER (H:6)	1	
4	67725-94500	.BOLT	1	
5	67726-94500	.NUT	2	
6	09100-08224	.BOLT	2	
7	09140-08016	.NUT	2	
8	67728-94500	.WASHER (9.8x18x2)	3	
9	09162-08007	.LOCK WASHER	2	

FIG. 34

FIG.34 (F-10) OPTIONAL

Q'TY

REMARKS

REF.NO.	PART NO.	DESCRIPTION	Q'TY	REMARKS
1	99000-31030	GASKET, liquid, No.4	1	100g
2	99000-31050	SUZUKI BOND, No.1	1	100g
3	99000-31120	SUZUKI SILICON SEAL	1	50g
4	99000-32050	THREAD LOCK CEMENT, super	1	50g
5-1	99000-25160	GREASE, water resistant	1	250g
5-2	99000-25170	GREASE, water resistant	1	50g
6	99000-22540	GEAR OIL, outboard motor	1	400cc
7	99000-25010	SUZUKI SUPER GREASE	1	450g
8	99000-32020	THREAD LOCK CEMENT, super	1	50g,103Q
9-1	99000-10109-01T	PAINT (FRANCOIS WHITE)	1	90g
9-2	99000-10209-02M	PAINT (Arctic Silver)	1	90g

